



## Utility Committee Meeting

### AGENDA

August 7, 2007

---

#### I. CALL TO ORDER

#### II. MATTERS BEFORE COMMITTEE

1. [Discussion - Increasing Septic Discharge Prices](#)
2. [Discussion - Comcast Fiber Optic Damage](#)
3. [Discussion - MEAG Project](#)
4. [Purchase - Line Truck](#)
5. [Purchase - RTX450 Trencher](#)
6. [Purchase of Backup System for Billing Data](#)
7. [MGAG - Legal Expenses](#)

#### III. ADJOURN



## Utility Committee Meeting

### AGENDA

August 7, 2007

**Item:**

Discussion - Increasing Septic Discharge Prices

**Department:**

Water and Gas

**Additional Information:**

**Financial Impact:**

**Budgeted Item:**

**Recommendation / Request:**

Discussion of increasing prices for Septic Discharge

Viewing Attachments Requires Adobe Acrobat. [Click here](#) to download.

**Attachments / click to download**

[Septic Discharge Pricing](#)

## Septic Discharge Pricing

Gallons (based on Tank size)	Current Price Effective 1-Apr-06 per discharge	Proposed Price Increase
275	\$ 12.00	\$ 21.00
400	\$ 18.00	\$ 31.50
500	\$ 18.00	\$ 35.00
650	\$ 24.00	\$ 42.00
700	\$ 30.00	\$ 52.50
900	\$ 36.00	\$ 63.00
1500	\$ 54.00	\$ 94.50
2000	\$ 78.00	\$136.50
2200	\$ 78.00	\$154.00
2500	\$ 90.00	\$157.50
2700	\$ 96.00	\$168.00
3000	\$108.00	\$189.00
3300	\$114.00	\$199.50
3500	\$126.00	\$220.50
4000	\$144.00	\$252.00
4500	\$162.00	\$283.50
5000	\$180.00	\$315.00
5500	\$198.00	\$346.50
6000	\$216.00	\$378.00
6500	\$234.00	\$409.50



## Utility Committee Meeting

### AGENDA

August 7, 2007

**Item:**

Discussion - Comcast Fiber Optic Damage

**Department:**

Water and Gas

**Additional Information:**

**Financial Impact:**

**Budgeted Item:**

**Recommendation / Request:**

Viewing Attachments Requires Adobe Acrobat. [Click here](#) to download.

**Attachments / click to download**

 [Comcast damaged fiber optic line](#)



Susana Rinner  
Phoenix Loss Control, Inc.

P.O. Box 27087  
Denver, CO 80227

Phone: 303-525-5054

July 13, 2007

**City of Monroe Public Works**  
**Attn: Damage Control/Risk Management**  
215 N Broad St  
Monroe, GA. 30655

RE: **Your file number:**  
**Our file number:** ATLPS-1975  
**Date of Damage:** 4/19/2007  
**Location of Damage:** Alcovy St & Ammons Bridge Rd, Monroe, GA.  
**Amount Owed:** \$ 21670.55

ATTN: Damage Claims Dept.,

Our company is handling the recovery interests of **Comcast**. Your company damaged Comcast's 138 count fiber optic cable while doing work at the above location on or about 4/19/07. Our on-scene damage investigator has indicated that locates were accurate at this location and we can provide photographs upon request by emailing [Susana\\_rinner@phoenixlosscontrol.com](mailto:Susana_rinner@phoenixlosscontrol.com).

Based on the information provided by the market, we have found you to be liable for this damage to Comcast's facilities. Please forward any information that may dispute our findings, or payment in full, within 21 days of receipt of this correspondence.

If you are insured, you may consider turning this matter over to your insurance carrier, otherwise payment is due within 21 days of this letter and invoice. Checks, Certified Money Orders, or Cashier's checks should be made payable to **Phoenix Loss Control, Inc.** and sent to **P.O. Box 27087, Denver, CO. 80227**. Please reference our file number at the top on your check. If you have questions or require additional information, please contact me at the number listed above, during normal business hours.

Sincerely,

A handwritten signature in black ink, appearing to read "Susana Rinner", is written over a circular stamp or seal.

**Susana Rinner**

Claims Manager  
Phoenix Loss Control, Inc.  
office/ 303-525-5054

[susana\\_rinner@phoenixlosscontrol.com](mailto:susana_rinner@phoenixlosscontrol.com)



## Utility Committee Meeting

### AGENDA

August 7, 2007

---

**Item:**

Discussion - MEAG Project

**Department:**

**Additional Information:**

**Financial Impact:**

**Budgeted Item:**

**Recommendation / Request:**

Viewing Attachments Requires Adobe Acrobat. [Click here](#) to download.

Attachments / click to download

---



## Utility Committee Meeting

### AGENDA

August 7, 2007

---

**Item:**

Purchase - Line Truck

**Department:**

Electric and Telecommunications

**Additional Information:**

**Financial Impact:**

**Budgeted Item:**

Budgeted Item

**Recommendation / Request:**

Viewing Attachments Requires Adobe Acrobat. [Click here](#) to download.

**Attachments / click to download**

- [Purchase of Line Truck](#)
- [Purchase of Line Truck](#)
- [Purchase of Line Truck](#)



## Quotation

Page 1 of 12

200 Edenway, White House, TN, 37188  
Phone: 800-672-4911 Fax: 615-616-1273

6/28/2007

Quote Number: 61800190

### Monroe Water Light & Gas Commission

215 N Broad Street  
PO Box 725  
Monroe GA 30655

Attention: Brian Thompson

Phone: 770-267-3429

Fax: 770-267-3698

Qty.	Description
1	Remote Sensor Bracket: * Bracket to be used with the Williams remote sensor. Installed to supply sensor to work with truck engine.
1	One (1) new Terex Telelect Commander 4047 model hydraulic rotating digger derrick with a turntable winch.  Design Criteria: * Terex Telelect digger derricks are designed in accordance with current industry and engineering standards applicable and accepted for structural and hydraulic design. * Meets ANSI A10.31-2006.  Elevation: * From +80 degrees above horizontal to -20 degrees below horizontal.  Pedestal And Turntable: * Square constructed pedestal has access holes for maintenance of hydraulic plumbing. The turntable is fabricated from high-strength steel utilizing thick side plates and a single-piece thick bottom plate. The bearing mounting surface is machined after welding to maintain a flat bearing mounting surface. The boom to turntable connection and lift cylinder to boom are equipped with self-aligning steel ball bushings.  Dual Lift Cylinders: * Double-acting cylinders with chrome plated rods and integral holding valves. Trapezoid mounting design offers greater boom support and stability providing less wear and longer life. Either cylinder can hold the rated lifting capacity of the derrick.  Steel Lower Boom: * The boom is a fabricated box utilizing high-strength steel plates.  Steel Intermediate Boom: * Fabricated box constructed of high strength steel. Powered by a double acting hydraulic cylinder equipped with integral holding valves on both extend and retract ports.

Item # 4



**Quotation  
61800190**

**Qty. Description**

Fiberglass Hydraulic Upper Boom:

- \* Capable of lifting the hydraulic capacity of the derrick in all positions.
- \* Certified for rated line voltage up to and including 46 KV AC.
- \* Tapered non-metallic rollers mounted at the end of the intermediate boom support the fiberglass boom under load minimizing scratches and abrasions. The sides of the fiberglass boom are supported and guided by non-metallic rollers to reduce tracking.

Boom Interlock:

- \* To operate the boom all outriggers must be extended.

Continuous And Unrestricted Rotation:

- \* Provided by worm gear drive through reversible hydraulic motor. Worm gear drive powers a special design long life hardened "shear ball" ball bearing rotation gear.

Hydraulic System:

- \* Tandem vane type high efficiency 3000 psi rated hydraulic pump providing 43.5 gallons per minute (at 2000 RPM and 2500 psi).
- \* 50 gallon hydraulic oil reservoir includes 10 micron replaceable cartridge type return line filter mounted in reservoir with bypass valve incorporated in filter to prevent restricted flow.
- \* A 100 mesh in screen in filter cap. A 40 mesh screen included in tank outlet and a 2 1/2" full flow gate type shut off valve.
- \* Glycerin filled pressure gauge to monitor circuit pressures.
- \* Relief valves to protect the derrick circuits and digger-winch circuits.
- \* Hydraulic hoses are equipped with permanent type hose fittings.

Miscellaneous:

- \* A custom load chart stating actual lifting capacity considering all final options, chassis, body, outriggers, and other fixed equipment with capacity based on completed unit stability is included.
- \* A boom-angle indicator and decal are mounted on each side of the lower boom.
- \* The entire unit is painted with rust inhibiting primer.
- \* Two complete manuals providing operational and maintenance procedures, and a replacement parts listing.
- \* Warning decals provided with unit.
- \* Clevis for two part line attachment.

Turntable Winch Including Transferable Pole Buddy Assembly:

- \* 15,000 lb. bare drum capacity worm gear winch equipped with hydraulic counterbalance valve mounted on the derrick turntable. Equipped with flanged pole buddy transferable from intermediate boom to upper boom.

Bare Boom Lift Capacities:

	All Booms Retracted	Intermediate Boom Extended	Intermediate & Upper Boom Extended
* Boom Angle:			
* Maximum Elevation	24630	17520	13280
* 10 Ft. Radius	11010	10020	9640
* 45 Degree Boom Angle	8450	5460	4050
* 0 Degree Boom Angle	5230	3180	2300

**Quotation**  
**61800190**

Page 3 of 12

<b>Qty.</b>	<b>Description</b>
	Sheave Height: <ul style="list-style-type: none"><li>* With intermediate boom extended, 38.6 ft. at maximum elevation.</li><li>* With upper boom extended, 47.4 ft. at maximum elevation.</li><li>* Dimensions are based on a 40" chassis frame height.</li></ul>
	Load Radius: <ul style="list-style-type: none"><li>* 28.5 ft. from C/L of rotation, at 0 degree, intermediate boom extended.</li><li>* 37.5 ft. from C/L of rotation, at 0 degree, upper boom extended.</li></ul>
1	48 Inch Pedestal: <ul style="list-style-type: none"><li>* To work with up to 63.75" cab heights on over rear axle mounts and up to 56.75" cab heights on behind cab units.</li></ul>
1	Command Post With "Exclusive Single Stick T" Control: <ul style="list-style-type: none"><li>* Control allows one hand to operate three functions: rotation, boom elevation, and intermediate boom extension.</li><li>* Upper boom extension and other functions have individual controls.</li><li>* Glycerin filled pressure gauge is provided to monitor system pressure.</li><li>* Permanent type control decals are provided.</li><li>* Adjustable cushioned operator seat is provided as standard and includes side rails.</li><li>* Hydraulic foot throttle.</li><li>* Command post access step and hand rail installed.</li></ul>
1	Remote Sensor Bracket: <ul style="list-style-type: none"><li>* Bracket to be used with the Williams remote sensor. Installed to supply sensor to work with truck engine.</li></ul>
1	Stop / start at command post.
1	12,000 ft-lb Two Speed Digger With Hydraulic Shift (ESK 76BA): <ul style="list-style-type: none"><li>* Planetary gear drive powered by reversible hydraulic motor:</li><li>* 60" long x 2-5/8" hex auger shaft with auger adjustment holes.</li><li>* Digger hanger bracket is box section and is equipped with a transfer protection system, auger stowage bracket with self latching auger catch, hydraulic auger release, and auger roll-up cable.</li><li>* The auger stowage bracket stores up to a 24" diameter auger, in the standard position.</li><li>* Telescopic trombone tube is provided to shift the two-speed digger hydraulically.</li><li>* Digger storage protection system to protect the auger storage cable from damage caused by over-winding. Oil from the digger system is returned to tank before the cable is over-stressed.</li></ul>
1	Pole Guide For Transferable Pole Buddy: <ul style="list-style-type: none"><li>* Unique circular design arms handle poles up to 23 in. diameter with the tips touching.</li><li>* Hydraulic cylinders equipped with holding valves operate the tilt and open/close on pole guide arms.</li><li>* Pole guide hoses are contained in a chain type carrier, installed on the side of the boom.</li><li>* Transfers from the end of the intermediate boom to the end of the upper boom and vice versa.</li><li>* The pole guide is installed on the transferable pole buddy flange assembly.</li></ul>
1	Pole Guide Interlock For Transferable Pole Guide: <ul style="list-style-type: none"><li>* Protects both the pole guide and the boom from accidental damage caused by extending the upper boom while the pole guide is on the intermediate boom and tilted downward. Includes actuating plunger and two poppet valves.</li></ul>

**Quotation**  
**61800190**

- | <b>Qty.</b> | <b>Description</b>  |
|-------------|---|
| 1           | Hydraulic Overload Protection For Rotation, Intermediate Boom, Upper Boom, Winch, Digger Dig & Boom Down:<br>* Helps prevent damage to derrick when overloads occur. These systems leave operational those functions necessary to eliminate the overload condition until it is relieved.<br>* The system is fully automatic relative to the operation and re-set functions. |
| 1           | Electric collector ring 4-conductor.  |
| 1           | Full length subframe for 120" CA chassis.   |
| 1           | Tie down kit.   |
| 1           | Extra Heavy Duty A-frame Outriggers:<br>* Hydraulic double acting outriggers including integral holding valves.<br>* 146.7 " spread pin to pin and 157.5 " to outside of pads at 9.6 " penetration and 40 " frame height.<br>* 13 " x 12 " swivel type stabilizer pads.   |
| 1           | Heavy Duty A-Frame Outriggers:<br>* Hydraulic double acting outriggers including integral holding valves.<br>* 144.4 " spread pin to pin and 155.9 " to outside of pads at 8 " penetration and 42 " frame height.<br>* 13 " x 12 " swivel type stabilizer pads.   |
| 1           | Controls For 2-Sets Of Outriggers And Auxiliary Tool Outlets Below Rotation (Diggers):<br>* Recessed at rear of truck each side for ease of view for outrigger placement.<br>* Includes switches and alarm for outrigger in motion alarm.   |

**UTILITY BODY**

- |   |   |
|---|---|
| 1 | LLB168 Utility Line Body:<br>A. Dimensions<br>-168" overall length<br>-94" outside width<br>-58" bed width<br>-28" floor to top of body<br>-18" compartment depth<br>-46" compartment height<br>-24" horizontal compartment height<br>B. Compartmentation - Street Side<br>-First Vertical (30") - 5 material hooks (1-3-1)<br>-Second Vertical (30") - 2 adjustable shelves with 5 adjustable dividers each<br>-Third Vertical (30") - 2 adjustable shelves with 5 adjustable dividers each<br>-Horizontal (54") - 8 adjustable dividers in compartment bottom<br>-Rear Vertical (24") - 5 material hooks (1-3-1)<br>C. Compartmentation - Curb Side<br>-First Vertical (30") - 5 material hooks (1-3-1)<br>-Second Vertical (30") - access steps to cargo area<br>-Third Vertical (30") - 2 adjustable shelves with 5 adjustable dividers each<br>-Horizontal (54") - 1 adjustable shelf with 8 adjustable dividers<br>-Rear Vertical (24") - 5 material hooks (1-3-1)<br>D. Features |
|---|---|

**Quotation  
61800190**

**Qty. Description**

- Full length shelf in top of street side compartments with rear drop door
- Wheel chock storage (2) each side in wheel wells
- Master door rod lock system
- 16-gauge A60 double-sided galvanized coated steel body exterior
- 18/16-gauge A60 double-sided galvanized coated steel door panels
- 12-gauge treadplate floor
- 12-gauge treadplate compartment tops
- Rotary door latches and full-length stainless steel rod door hinge
- Chain stops on doors and includes automotive bulb-type door seals

- 1 Frame and floor with installation of subframe and outriggers.
- 1 Add a 2" lip around the tail shelf with corners notched for drainage.
- 9 VISTA strip compartment light.
- 1 Tail shelf 30" long with 12-gauge treadplate top and smooth sides.
- 2 Grab handle for stair type side access steps.
- 4 Pool type pipe grab rail for tailshelf or rear of flatbed.
- 1 Access steps to command post or platform.
- 1 Rigid type perf-grip stirrup step.
- 2 Cable type gripstrut stirrup step.
- 4 Laminated wood outrigger pad 24" x 24" x 2-1/4" with rope handle.
- 4 Outrigger pad storage brackets.
- 4 Rubber wheel chocks with eye bolt.
- 2 Cone holder brackets on front bumper, cone type.

**INSTALLATION & ACCESSORIES**

- 1 Install Derrick Over Rear Axle And Install All Associated Components:  
\* Final test and inspect completed unit including stability and dielectric testing per manufacturers requirements and ANSI A10.31.
- 1 Hose and fittings to connect the hydraulic system from the oil reservoir to the pump and unit.
- 1 Hydraulic pump.
- 60 Hydraulic oil and lubricants.  
\* Refer to the product maintenance manual for specific type to be used.

**Quotation  
61800190**

Page 6 of 12

<b>Qty.</b>	<b>Description</b>
1	Power take off, 10-bolt, with indicator light for Allison MD automatic transmission.
1	Hannay spring loaded hydraulic hose reel with 4-way roller assembly.
1	Dual Hose Assembly For Hose Reel: * 35' of 1/2" ID hose * Parker HTMA male and female flush faced couplers and dust covers. * Installed on hose reel with ball stop.
1	Boom rest for digger derrick.
2	Hour meter for power take off engagement time and engine hours.
1	Peterson 7-lamp DOT Lighting Package: * Complies with FMVSS 108. * Includes required lights, junction box, wiring harness and mounting light bar.
2	Preco 4242A amber strobe light with 4" tall & 6" dia. lens and mounting bracket.
2	Preco BG4240 branch guard for 4" strobe.
1	Midland 7-prong trailer socket.
2	Unity AG-R-H halogen 6" spotlight with mounting bracket. Locate one on each side of boom rest.
4	Whelen LED 4.5" round flush mounted amber strobe light. Two in front winch and two in rear light bar.
1	DOT Inspection.
1	Set chassis parameters.
1	One pair of mud flaps with logo.
1	Remote engine stop / start control from rear of vehicle.
1	Back-up alarm to sound when the vehicle is shifted into reverse.
1	Push button throttle control installed.
1	BP100A 15 ton pintle hook: * Safety chain eyes. * Chassis frame reinforcements.
1	Texoma 18 TXD104-48 auger, 18" with steel blade teeth, 5/16" flighting and 2-5/8" hex bushing.
1	Chance 7' drive end wrench capacity, 15,000-lb capacity.
1	Chance screw anchor locking dog assembly, 15,000-lb capacity.
1	Chance screw anchor drive end assembly, 15,000# capacity.

Item # 4

**Quotation**  
**61800190**

<b>Qty.</b>	<b>Description</b>
1	Chance screw anchor adapter, 2-5/8" hex, 15,000-lb capacity.
1	100' of 1-1/8" Samson uncoated stable braid rope.
1	Gunnebo Johnson 7JH swivel hook.
1	Pole rack on street side with two ratchets and 2" wide webbing tie down straps to secure pole.
1	Amerex 5-lb ABC fire extinguisher with bracket.
1	Orion flare kit with holder.
1	James King triangle reflector kit.
1	Paint body floor with non-skid paint.
1	Paint compartment top with non-skid paint.
1	Paint line body one color.
1	Paint derrick one color.
1	Paint front winch one color.
1	2007 INTERNATIONAL 4300 4X2, 33,000 GVWR (Spec # 10 HD)
	Wheelbase/CA Wheelbase 187", CA 120", axle to frame 100"
	Frame Frame rails heat treated alloy steel, 120,000 psi yield Tow hooks, front (2) inside rail, frame mounted Bumper, front full width, aerodynamic, steel, powder coated Gray (Argent) color
	Axle/Suspension, Front Axle, non-driving International, I-Beam Type, 13,000-lb capacity Suspension, spring parabolic, taper leaf; 13,000-lb capacity; with shock absorbers Springs, auxiliary rubber
	Axle/Suspension, Rear Axle, single, single reduction, 20,000-lb capacity, 190 wheel ends, gear ratio 6.17 Suspension, vari-rate, 23,500-lb capacity, with 4500 lb auxiliary rubber spring
	Brakes/Brake Equipment Air brake ABS antilock brake system, full vehicle wheel control system, 4-channel Slack adjusters, automatic front and rear Parking brake, control valve on instrument panel Drain valve, twist type Air dryer, with heater Air compressor, 13.2 cfm

**Quotation  
61800190**

Page 8 of 12

<b>Qty.</b>	<b>Description</b>
	Dust shields, front and rear
	Engine/Engine Equipment
	Engine, diesel, International DT466, 50 state, 245 HP, 620 lb-ft torque at 1400 rpm, 2600 rpm governed speed
	Gauge, air cleaner restriction
	Fuel/water separator and fuel filter
	Cold starting equipment, intake manifold electric grid heater with engine ECM control
	Wet type cylinder sleeves
	Cruise control, electronic
	Governor, road speed, electronic
	Fan drive viscous screw on type
	Radiator with charge air cooler and with in-tank transmission cooler, deaeration system with surge tank
	Federal emissions for 2004, for International DT466 engines
	Fan drive special effects, fan cooling ring with fan shroud effects
	Expanded engine temperature effects, to allow higher engine operating temperature range, includes nylon surge tank and 15 psi pressure cap
	Block heater, engine, 120 volt, 1250 watt
	Throttle, hand control, engine speed control for PTO, electronic, stationary pre-set, two speed settings
	Transmission
	Transmission, automatic Allison 3000 RDS P, close ratio, 5-speed, with overdrive, on/off hwy, includes oil level sensor, with PTO provision, less retarder
	Transmission shift control, Allison, push-button type
	Allison spare input/output for rugged duty series (RDS)
	Gauge, transmission oil temperature
	Oil cooler, automatic transmission, air to oil type
	Exhaust
	Exhaust system, single, horizontal, stainless steel muffler with internal catalytic converter, short tail pipe, frame mounted left side
	Electrical
	Electrical system, 12 volt
	Fuses, SAE blade type
	Starter switch electric key operated
	Data link connector for vehicle programming and diagnostics in cab
	Windshield wipers, 2-speed with wash and intermittent feature
	Cigar lighter
	Alternator, 12 Volt, 110 amp capacity
	Body builder wiring back of standard cab at left frame or under extended or crew cab at left frame, sealed connectors for tail/amber turn/marker/ backup/accessory power/ground and sealed connector for stop/turn
	Electric trailer brake/lights accommodation package to rear of frame for combined trailer stop, tail, turn, marker light circuits; includes electric trailer brake accommodation package with cab connections for mounting customer installed electric brake unit, less trailer socket
	Trailer auxiliary feed circuit for electric trailer brake accommodation/air trailer ABS, with 30 amp fuse and relay, controlled by ignition switch
	Battery system, (3) maintenance-free, 12 volt, 1950 CCA total
	Switch, toggle, for work light and wiring effects for customer furnished back of cab light

Item # 4

**Quotation  
61800190**

Page 9 of 12

<b>Qty.</b>	<b>Description</b>
	Fuel Tank Fuel tank, D style, steel, 50 gallon, mounted right side, under cab
	Seats Seat, front bench, full width, vinyl, with fixed mid back
	Cab Equipment Cab conventional, steel Air conditioner, International Blend-Air with integral heater and defroster Glass, all windows tinted Radio, AM/FM stereo with Weatherband and clock Steering, power, stationary column Horn, air, single trumpet, mounted behind bumper on right rail Front end tilting, fiberglass, with three piece construction Grille, chrome Gauge cluster, Odometer Display: miles, trip miles, engine hours, trip hours, and fault code readout, Warning System: low fuel, low oil pressure, high engine coolant temp, and low battery voltage, Gauge Cluster: engine oil pressure, water temperature, fuel, tachometer, voltmeter, and speedometer Mirrors, two Lang Mekra, 7.44" x 14.84", brackets breakaway type, with 102" wide spacing, with 7.44" sq. convex both sides Console, overhead, dual storage pockets and retainer Dome light, cab door activated, timed theater dimming Sun visors, two padded vinyl Storage pocket, drivers door Grab handles, cab mounted left and right for entry Paint, type base coat/clear coat, 9219 Winter White
	Wheels/Tires Front Wheels, disc, 22.5" x 8.25", White painted steel, 10 stud, wheel seals, grease lubricated, includes wheel bearings (2) Tires, 11R22.5 G149 RSA, Goodyear, load range G, 14 ply
	Wheels/Tires Rear Wheels, dual disc; 22.5" x 8.25", White painted steel, 10 stud, wheel seals, oil lubricated, includes wheel bearings (4) Tires, 11R22.5 G362 Goodyear, load range G, 14 ply
	Body Builder Features Engine control, remote mounted provision for, includes module and connector for body builder installation of remote engine speed control, with SAE J1939 communication BDY INTG, remote power module, mounted under cab up to six outputs and six inputs, maximum 20 amps per channel, maximum 80 amp total, includes one switch pack with latched switches BDY INTG, remote start/stop, to start and stop vehicle engine, will start emergency pump motor, programmable time intervals BDY INTG, PTO accommodation for electric over hydraulic PTO, does not include solenoids, with switch mounted on dash, includes audible alarm and indicator light in gauge cluster, requires one remote power module input and one output BDY INTG, indicator lights, two, one for boom out of stow and one for outriggers deployed, includes audible alarm and interlock to parking brake, programmable mode for various switch actions, requires two remote power module inputs

Item # 4



**Quotation**  
**61800190**

Page 10 of 12

<b>Qty.</b>	<b>Description</b>
1	Braden PD18C-11DB FEB Hydraulic Planetary Front Mounted Bumper Winch Including: * 20,000-lb rated capacity. * Extended shaft to curb side for take-up reel. * Four way roller assembly. * 200' of 1/2" 6x19 wire rope with eye. * Winch valve, air actuator, miscellaneous hose and fittings. Winch package from Sam Winer #05370
1	Collapsible Take-up Reel: * 4,000-lb maximum pulling force. * 20" diameter, 28" overall. * Bayonet style socket fits 2-7/16" shaft.
1	Winch control installed in chassis cab.
1	Hydraulic Tamp. STNSHTA54103. With 65303793 and 65303794 hydraulic couplings.

**Quotation  
61800190**

Page 11 of 12

**Qty. Description**

**Grand Total:**

**\$162,007.00**

**Notes:**

1. Prices are FOB Shipping Point, with freight prepaid to Destination.
2. Prices exclude any applicable taxes or license fees.
3. Federal Excise Tax has not been included. A current exemption/resale certificate must be on file and provided with purchase order for tax exempt sale. Federal Excise Tax will be added if certificate is not supplied with order.
4. Terms: Net 10 days with pre-approved credit.
5. Chassis pricing is based upon current model year production availability. Any Federal mandated costs, such as 2007 emission requirements, will be passed on at cost.
6. Chassis payment is due upon chassis receipt at our facility.
7. Quotation good for 30 days. Contact us for a possible extension if required.
8. Delivery from receipt of order approximately 60 to 90 days on this special unit only.
9. Terex Telelect is ISO 9001:2000 Certified.

**Terex Utilities, Inc.**  
*Steve Hertzler*

\_\_\_\_\_  
**Steve Hertzler – Order Coordinator**

**Account Manager – Jerald Phillips**

**Accepted By:**

\_\_\_\_\_

**PO Number:** \_\_\_\_\_

**Date:** \_\_\_\_\_

**Quotation  
61800190**

Page 12 of 12

## **TEREX-TELELECT WARRANTY**

### **All Products**

TEREX-TELELECT, INC. ("TEREX-TELELECT") hereby warrants all equipment manufactured and supplied by TEREX-TELELECT to be free from defects in material and workmanship at the time of shipment from the TEREX-TELELECT plant. TEREX-TELELECT will repair or replace, at TEREX-TELELECT's sole option, at its plant or network location any equipment which shall, within **TWELVE (12) MONTHS** after delivery to the original customer, but not to exceed **EIGHTEEN (18) MONTHS** from date of shipment from TEREX-TELELECT, be returned to TEREX-TELELECT's plant and be found by TEREX-TELELECT to have been defective at the time of original shipment from TEREX-TELELECT. *(Excludes seals, gaskets, hoses, and exterior coatings beyond 12 months)*

The following structural members have a **LIFETIME** parts only warranty for the original owner after date of shipment from TEREX-TELELECT: Sub frame, Pedestal, Turntable, Steel and Fiberglass Booms. The **LIFETIME** warranty requires an annual service inspection by an authorized TEREX-TELELECT distributor and all replacement parts to be original equipment parts from TEREX-TELELECT. The above listed components shall have a **FIVE (5) YEAR** parts only warranty if the annual service inspection is performed by an approved entity other than an authorized TEREX-TELELECT distributor. All replacement parts are to be original equipment parts from TEREX-TELELECT.

*(Excludes fiberglass jibs, seals, gaskets, hoses, and exterior coatings.)*

**DISCLAIMER:** THIS WARRANTY IS IN LIEU OF ALL OTHER WARRANTIES, EXPRESS OR IMPLIED, INCLUDING WITHOUT LIMITATION ANY IMPLIED WARRANTY OF MERCHANTABILITY OR FITNESS FOR A PARTICULAR PURPOSE, AND IS ALSO IN LIEU OF ANY OTHER OBLIGATIONS ON THE PART OF TEREX-TELELECT. No agent, employee or representative of TEREX-TELELECT is authorized to bind TEREX-TELELECT to any other warranty.

This Warranty shall not apply with respect to any claimed defect which in TEREX-TELELECT's sole judgment has arisen from repair or alteration or from damage during shipment, accident, negligence, overloading, or misuse, including, but not limited to, operator's failure to follow any of the instructions issued with the equipment. '

**LIMITATION OF LIABILITY:** TEREX-TELELECT'S LIABILITY FOR ANY LOSSES AND DAMAGES RESULTING FROM ANY CAUSE WHATSOEVER, INCLUDING WITHOUT LIMITATION TEREX-TELELECT'S NEGLIGENCE OR FROM DAMAGED OR DEFECTIVE EQUIPMENT, IRRESPECTIVE OF WHETHER SUCH DEFECTS ARE DISCOVERABLE OR LATENT, SHALL IN NO EVENT EXCEED THE PURCHASE PRICE OF THE PARTICULAR EQUIPMENT TO WHICH LOSSES OR DAMAGES ARE CLAIMED, OR, AT THE ELECTION OF TEREX-TELELECT, THE REPAIR OR REPLACEMENT OF THE DEFECTIVE OR DAMAGED EQUIPMENT.

IN NO EVENT SHALL TEREX-TELELECT BE LIABLE FOR ANY SPECIAL, INCIDENTAL OR CONSEQUENTIAL DAMAGES INCLUDING WITHOUT LIMITATION COMMERCIAL LOSSES OR COSTS OF ANY KIND OR FOR ANY DAMAGES FOR WHICH BUYER MAY BE LIABLE TO OTHER PERSONS.

There are no express or implied warranties, including the WARRANTY OF MERCHANTABILITY AND FITNESS FOR A PARTICULAR PURPOSE, covering components, parts or accessories manufactured by someone else other than TEREX-TELELECT. Such warranties as may be furnished to TEREX-TELELECT by the manufacturer of such items will be extended to buyer by TEREX-TELELECT.

TEREX-TELELECT reserves the right to make changes in design or construction of its equipment at any time without obligating itself to make such changes on equipment previously manufactured.

In the event any provision of the warranty is for any reason held ineffective, the remaining provisions shall remain in full force and effect.

**INTERNATIONAL®**

**February 09, 2006**

**Prepared For:**

Altec Industries \*

31 Inverness Center Pkwy. Ste. 360  
Birmingham, AL 35242-4875  
(205)323 - 8751  
Reference ID: 400 Ref 2006

**Presented By:**

Southland International Trucks, Inc.  
Ross M OMalley  
200 Ormoor Blvd.  
Homewood AL 35209  
(205)942-6226

**Model Profile**  
**2007 4300 SBA 4X2 (MA025)**

**APPLICATION:**

Utility/Service (Other)

**MISSION:**

Requested GVWR: 33000. Calc. GVWR: 33000  
Calc. Start / Grade Ability: 26.10% / 2.37% @ 55 MPH  
Calc. Geared Speed: 67.6 MPH

**FUEL ECONOMY:**

7.44 MPG @ 55 MPH

**DIMENSION:**

Wheelbase: 187.0, CA: 119.9, Axle to Frame: 114.0

**ENGINE, DIESEL:**

{International DT466} 50 State, 245 HP, 620 lb-ft Torque @ 1400 RPM, 2600 RPM Governed Speed, # 2 Bell Housing

**TRANSMISSION, AUTOMATIC:**

{ALLISON 3000\_RDS\_P} 4th Generation Controls; Close Ratio, 5-Speed, With Overdrive; On/Off Hwy; Includes Oil Level Sensor, With PTO Provision, Less Retarder, With 80,000-lb GVW & GCW Max.

**CLUTCH:**

Omit Item (Clutch & Control)

**AXLE, FRONT NON-DRIVING:**

{Dana Spicer I-130S} I-Beam Type, 13,000-lb Capacity

**AXLE, REAR, SINGLE:**

{Dana Spicer 21060S} Single Reduction, 20,000-lb Capacity, 190 Wheel Ends Gear Ratio: 6.17

**CAB:**

Conventional, Steel

**TIRE, FRONT:**

(2) 11R22.5 G149 RSA (GOODYEAR) 501 rev/mile, load range H, 16 ply

**TIRE, REAR:**

(4) 11R22.5 G164 RTD M+S (GOODYEAR) 499 rev/mile, load range G, 14 ply

**SUSPENSION, RR, SPRING, SINGLE:**

Vari-Rate; 23,500-lb Capacity, With 4500 lb Auxiliary Rubber Spring

**PAINT:**

Cab Schematic 100GA

Location 1: 9219, Winter White

Chassis Schematic N/A

<b>Code</b>	<b>Description</b>
MA02500	Base Chassis, Model 4300 SBA 4X2 with 187.0 Wheelbase, 119.9 CA, and 114.0 Axle to Frame.
1570	TOW HOOK, FRONT (2) Inside Rail, Frame Mounted.
1CAE	FRAME RAILS Heat Treated Alloy Steel (120,000 PSI Yield); 10.125" x 3.580" x 0.312" (257.2mm x 90.9mm x 8.0mm); 456.0" (11582mm) Maximum OAL
1LLD	BUMPER, FRONT Full Width, Aerodynamic, Steel; 0.142" Material Thickness  <u>Includes</u> : PLEASE NOTE: Powder Coated Gray (Argent) Color
1SAL	CROSSMEMBER, REAR, AF (01)
1WEH	WHEELBASE RANGE 134" (340cm) Through and Including 197" (500cm)
2AGV	AXLE, FRONT NON-DRIVING {Dana Spicer I-130S} I-Beam Type, 13,000-lb Capacity
3770	SPRINGS, FRONT AUXILIARY Rubber
3AGS	SUSPENSION, FRONT, SPRING Parabolic, Taper Leaf; 13,000-lb Capacity; With Shock Absorbers
4091	BRAKE SYSTEM, AIR Dual System for Straight Truck Applications  <u>Includes</u> : AIR COMPRESSOR AIR SUPPLY LINE International Engines Naturally-Aspirated : BRAKE CHAMBERS, SPRING (2) Rear Parking : BRAKE LINES Color Coded Nylon : DRAIN VALVE Twist-Type : GAUGE, AIR PRESSURE Air 1 and Air 2 Gauges; Located in Instrument Cluster : PARKING BRAKE VALVE Color-Coded Yellow Knob, Located on Instrument Panel : SLACK ADJUSTERS, FRONT Automatic : SLACK ADJUSTERS, REAR Automatic : SPRING BRAKE MODULATOR VALVE
4619	TRAILER CONNECTIONS Four-Wheel, With Hand Control Valve and Tractor Protection Valve, for Straight Truck
4AZA	AIR BRAKE ABS {Bendix AntiLock Brake System} Full Vehicle Wheel Control System (4-Channel)
4EBS	AIR DRYER {Bendix AD-9} With Heater
4JBG	BRAKES, FRONT, AIR CAM S-Cam; 15.0" x 4.0"; Includes 20 Sq. In. MGM Long Stroke Brake Chambers
4NCE	BRAKES, REAR, AIR CAM 16.5" x 7.0"; Includes MGM TR3030 Long Stroke Brake Chamber and Heavy Duty Spring Actuated Parking Brake
4SBC	AIR COMPRESSOR {Bendix Tu-Flo 550} 13.2 CFM Capacity
5708	STEERING COLUMN Tilting
5CAL	STEERING WHEEL 2-Spoke, 18" Diam., Black
5PSA	STEERING GEAR {Sheppard M-100} Power
7BBG	EXHAUST SYSTEM Single, Horizontal, Stainless Steel Muffler with Internal Catalytic Converter, Short Tail Pipe; Frame Mounted Left Side; for 2004 Emissions Standard with International I6 Engines
8000	ELECTRICAL SYSTEM 12-Volt, Standard Equipment  <u>Includes</u> : DATA LINK CONNECTOR For Vehicle Programming and Diagnostics In Cab : FUSES, ELECTRICAL SAE Blade-Type : HORN, ELECTRIC Single : PARKING LIGHT Integral with Front Turn Signal and Rear Tail Light : STARTER SWITCH Electric Key Operated

**INTERNATIONAL®****Vehicle Specifications**  
**2007 4300 SBA 4X2 (MA025)****February 09, 2006**

<u>Code</u>	<u>Description</u>
	: STOP, TURN, TAIL & B/U LIGHTS Dual, Rear, Combination with Reflector
	: TURN SIGNAL SWITCH Self-Cancelling, Headlight Dimmer (with Flash-To-Pass Feature)
	: TURN SIGNALS, FRONT Includes Reflectors and Auxiliary Side Turn Signals, Solid State Flashers; Flush Mounted
	: WINDSHIELD WIPER SWITCH 2-Speed with Wash and Intermittent Feature, Integral with Turn Signal Switch
	: WINDSHIELD WIPERS Single Motor, Electric, Cowl Mounted
	: WIRING, CHASSIS Color Coded and Continuously Numbered
8518	CIGAR LIGHTER
8540	HORN, ELECTRIC (2)
8GEJ	ALTERNATOR {Leece-Neville 8LHP2172VAH} Brush Type; 12 Volt 110 Amp. Capacity, Pad Mounted
8HAB	BODY BUILDER WIRING Back of Standard Cab at Left Frame or Under Extended or Crew Cab at Left Frame; Includes Sealed Connectors for Tail/Amber Turn/Marker/ Backup/Accessory Power/Ground and Sealed Connector for Stop/Turn
8MEZ	BATTERY SYSTEM {International} Maintenance-Free, (2) 12-Volt 1850CCA Total
8RGS	RADIO {International} AM/FM Stereo With Weatherband, Clock, Includes Multiple Dual Cone Speakers
	<u>Includes</u>
	: SPEAKERS IN CAB (2) Dual-Cone with Deluxe Interior
	: SPEAKERS IN CAB (4) Coaxial with Premium Interior
8TMG	TRAILER CONNECTION SOCKET 7-Way; Mounted at rear of Frame, Wired for Turn Signals Combined With Stop, Compatible With Trailers That Use Combined Stop, Tail, Turn Lamps
8WCL	HORN, AIR {Grover} Black, Single Trumpet, Air Solenoid Operated, Mounted Behind Bumper on Right Rail
8WPB	HEADLIGHTS Halogen; Composite Aero Design for Two Light System; Includes Daytime Running Lights
8WWN	STARTING MOTOR {Leece-Neville M100R} 12-Volt; less Thermal Over-Crank Protection
9HAD	GRILLE Chrome
9WAY	FRONT END Tilting, Fiberglass, With Three Piece Construction
10060	PAINT SCHEMATIC, PT-1 Single Color, Design 100
	<u>Includes</u>
	: PAINT SCHEMATIC ID LETTERS "GA"
10761	PAINT TYPE Base Coat/Clear Coat, 1-2 Tone
11001	CLUTCH Omit Item (Clutch & Control)
12959	BLOCK HEATER, ENGINE {Phillips} 120 Volt/1250 Watt
	<u>Includes</u>
	: BLOCK HEATER SOCKET Receptacle Type; Mounted below Drivers Door
12NPP	ENGINE, DIESEL {International DT466} 50 State, 245 HP, 620 lb-ft Torque @ 1400 RPM, 2600 RPM Governed Speed, # 2 Bell Housing
	<u>Includes</u>
	: COLD STARTING EQUIPMENT Intake Manifold Electric Grid Heater with Engine ECM Control
	: CRUISE CONTROL Electronic; Controls Integral to Steering Wheel
	: DAMPER, CRANKSHAFT Viscous
	: ENGINE OIL DRAIN PLUG Magnetic
	: ENGINE SHUTDOWN Electric, Key Operated
	: FAN Optimized Position
	: FUEL/WATER SEPARATOR and FUEL FILTER in a Single Assembly, Mounted on Engine
	: GAUGE, AIR CLEANER RESTRICTION Air Cleaner Mounted

**INTERNATIONAL®****Vehicle Specifications**  
**2007 4300 SBA 4X2 (MA025)****February 09, 2006**

<b><u>Code</u></b>	<b><u>Description</u></b>
	: GOVERNOR Road Speed, Electronic : OIL FILTER, ENGINE Spin-On Type : WET TYPE CYLINDER SLEEVES
12TSY	FAN DRIVE {Borg-Warner SA85} Viscous Screw On Type  <u>Includes</u> : FAN Nylon
12UWV	RADIATOR Aluminum; 2-Row, Cross Flow, Over Under System, 516 SqIn Louvered, With 270 SqIn Charge Air Cooler, 4.25" Core, With In-Tank Transmission Cooler  <u>Includes</u> : ANTI-FREEZE Shell Rotella Extended Life Coolant -40F (-40C) : DEAERATION SYSTEM with Surge Tank : RADIATOR HOSES Premium, Rubber
12UXV	FEDERAL EMISSIONS for 2004; for International VT365, DT466 and DT570 Engines
12VBC	AIR CLEANER Single Element
12VXU	THROTTLE, HAND CONTROL Engine Speed Control for PTO; Electronic, Stationary Pre-Set, Two Speed Settings; Mounted on Steering Wheel
12VXY	ENGINE CONTROL, REMOTE MOUNTED Provision for; Includes Module and Connector for Body Builder Installation of Remote Engine Speed Control, With SAE J1939 Communication
12WTA	FAN DRIVE SPECIAL EFFECTS Fan Cooling Ring with Fan Shroud Effects, Engine Mounted
12WYS	EXPANDED ENGINE TEMP EFFECTS to Allow Higher Engine Operating Temperature Range; Includes Nylon Surge Tank and 15 psi Pressure Cap
13703	OIL COOLER, AUTO TRANSMISSION Air to Oil Type; for Auto or Auto Shift Transmissions
13AJE	TRANSMISSION, AUTOMATIC {ALLISON 3000_RDS_P} 4th Generation Controls; Close Ratio, 5-Speed, With Overdrive; On/Off Hwy; Includes Oil Level Sensor, With PTO Provision, Less Retarder, With 80,000-lb GVW & GCW Max.  <u>Includes</u> : TRANSMISSION OIL PAN Magnet in Oil Pan
13WBL	TRANSMISSION SHIFT CONTROL {ALLISON} Push-Button Type; for Allison 3000 & 4000 Series Transmission
13WUC	ALLISON SPARE INPUT/OUTPUT for Rugged Duty Series (RDS); General Purpose Trucks, Construction
14AGY	AXLE, REAR, SINGLE {Dana Spicer 21060S} Single Reduction, 20,000-lb Capacity, 190 Wheel Ends  <u>Includes</u> : REAR AXLE DRAIN PLUG (1) Magnetic
14VAH	SUSPENSION, RR, SPRING, SINGLE Vari-Rate; 23,500-lb Capacity, With 4500 lb Auxiliary Rubber Spring
15LJM	FUEL/WATER SEPARATOR {Fleetguard} With Thermostatic Fuel Temperature Controlled Electric Heater, and Filter Restriction/Change Indicator, Includes Standard Equipment Water-in-Fuel Sensor
15SCD	FUEL TANK Top Draw; D Style, Steel, 50 U.S. Gal., 189 L Capacity, 16" Deep, With Quick Connect Outlet, Mounted Right Side, Under Cab  <u>Includes</u> : FUEL LINES Nylon Tubing With O-Ring Snap-On Quick-Connect Fittings at Both Ends
16030	CAB Conventional, Steel  <u>Includes</u> : ARM REST (2) Molded Plastic, Smoke Gray; One Each Door

**INTERNATIONAL®****Vehicle Specifications**  
**2007 4300 SBA 4X2 (MA025)****February 09, 2006**

<b><u>Code</u></b>	<b><u>Description</u></b>
	: CLEARANCE/MARKER LIGHTS (5) Flush Mounted : COAT HOOK Located on Rear Wall, Centered Above Rear Window : FLOOR COVERING Rubber, Black : GLASS, ALL WINDOWS Tinted : GRAB HANDLE, CAB INTERIOR (1) "A" Pillar Mounted, Passenger Side : GRAB HANDLE, CAB INTERIOR (2) "B" Pillar Mounted, One Each Side : STEP (2) Two Steps Per Door
16HBA	GAUGE CLUSTER English With English Electronic Speedometer  <u>Includes</u> : GAUGE CLUSTER (5) Engine Oil Pressure (Electronic), Water Temperature (Electronic), Fuel (Electronic), Tachometer (Electronic), Voltmeter : ODOMETER DISPLAY, Miles, Trip Miles, Engine Hours, Trip Hours, Fault Code Readout : WARNING SYSTEM Low Fuel, Low Oil Pressure, High Engine Coolant Temp, and Low Battery Voltage (Visual and Audible)
16JDY	SEAT, DRIVER {Gra-Mag} Non-Suspension, High Back With Integral Headrest, Vinyl, With Fixed Back  <u>Includes</u> : SEAT BELT 3-Point, Lap and Shoulder Belt Type
16PHJ	SEAT, TWO-MAN PASSENGER {Gra-Mag} With Two Integral Headrest, Vinyl, With Fixed Back, Less Under Seat Storage Compartment  <u>Includes</u> : SEAT BELT (2) One 3-Point Shoulder Belt and One 2-Point Lap Belt (Center Position)
16SDJ	MIRRORS (2) {Lang Mekra} Rectangular, 7.44" x 14.84", Brackets Breakaway Type, With 102" Wide Spacing, With 7.44" sq. Convex Both Sides
16WJS	INSTRUMENT PANEL Center Section, Flat Panel
16WKB	AIR CONDITIONER {International Blend-Air} With Integral Heater & Defroster  <u>Includes</u> : HEATER HOSES Premium : REFRIGERANT Hydrofluorocarbon HFC-134A
16WRX	CAB INTERIOR TRIM Deluxe  <u>Includes</u> : "A" PILLAR COVER Molded Plastic, Smoke Gray : CAB INTERIOR TRIM PANELS Molded Plastic, Full Height; All Exposed Interior Sheet Metal is Covered Except for the Following: with a Two-Man Passenger Seat the Back Panel is Only Partially Covered and with a Full Bench Seat the Back Panel is : CONSOLE, OVERHEAD Molded Plastic with Dual Storage Pockets and Retainer Nets and CB Radio Pocket; Smoke Gray with Black Netting Over Storage Pockets : DOME LIGHT, CAB Rectangular, Door Activated, Timed Theater Dimming, Center Mounted, Integral to Console : DOOR TRIM PANELS (2) Molded Plastic; Driver and Passenger Doors : HEADLINER Printed Cloth : INSTRUMENT PANEL TRIM Molded Plastic, Drawbridge Gray with Black Center Section, Hidden Cup Holder and Ash Tray (Pull-Out) : STORAGE POCKET, DOOR (1) Molded Plastic, Smoke Gray, Full-Length; Driver Door : SUN VISOR (2) Padded Vinyl with Driver Side Toll Ticket Strap, Integral to Console
27DMA	WHEELS, FRONT DISC; 22.5" Painted Steel, 2 Hand Hole, 10 Stud (285.75MM BC) Hub Piloted, Flanged Nut, Metric Mount, 8.25 DC Rims; With Steel Hubs.  <u>Includes</u> : PAINT IDENTITY, FRONT WHEELS White : WHEEL SEALS, FRONT Grease Lubricated, Includes Wheel Bearings



**INTERNATIONAL®**

**Vehicle Specifications**  
**2007 4300 SBA 4X2 (MA025)**

**February 09, 2006**

<b><u>Code</u></b>	<b><u>Description</u></b>
28DMA	WHEELS, REAR DUAL DISC; 22.5" Painted Steel, 2 Hand Hole, 10-Stud (285.75MM BC) Hub Piloted, Flanged Nut, Metric Mount, 8.25 DC Rims; With Steel Hubs  <u>Includes</u> : PAINT IDENTITY, REAR WHEELS White : WHEEL SEALS, REAR Oil Lubricated, Includes Wheel Bearings
7372130116	(4) TIRE,REAR 11R22.5 G164 RTD M+S (GOODYEAR) 499 rev/mile, load range G, 14 ply
7382130155	(2) TIRE,FRONT 11R22.5 G149 RSA (GOODYEAR) 501 rev/mile, load range H, 16 ply  *  steel surcharge

**ENGINE/TRANSMISSION MATCHING**

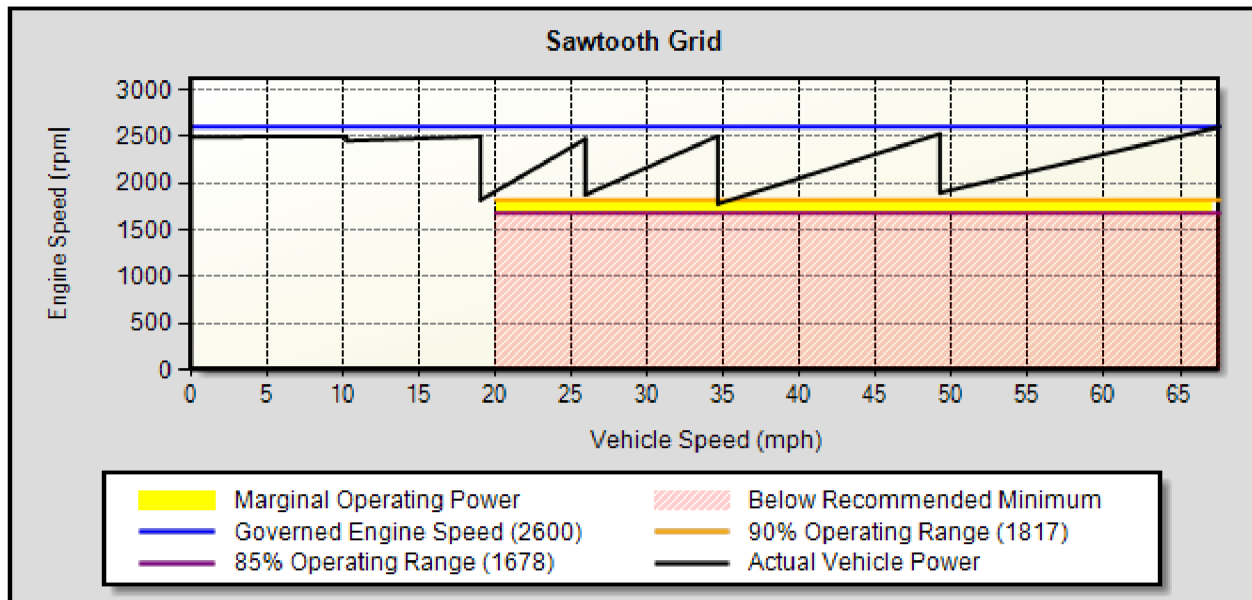

**Sawtooth Details**

Gear	Trans Ratio	Upshift Power Avail		Govern Power Avail		Peak Power Comparison			Warn Msg
		Veh Spd (MPH)	Eng Spd (RPM)	Veh Spd (MPH)	Eng Spd (RPM)	Gear Step (%)	85% Range (%)	90% Range (%)	
1C	3.49	0.0	2493.8	10.2	2498.4	N/A	55	43	
2C	1.86	10.2	2450.0	19.0	2497.5	N/A	55	43	
2L	1.86	19.0	1815.4	25.9	2470.1	N/A	55	43	
3L	1.41	25.9	1872.5	34.6	2501.3	N/A	55	43	
4L	1.00	34.6	1774.0	49.2	2525.0	N/A	55	43	
5L	0.75	49.2	1893.8	67.6	2600.0	N/A	55	43	

@ - WHEELSLIP CAN OCCUR AT THE GRADE SHOWN. THE VEHICLE IS CAPABLE OF INCREASED GRADEABILITY IF MORE WEIGHT IS PLACED ON THE DRIVE AXLES.

**STEADY STATE PERFORMANCE**

<b>Performance Results</b>	<b>Gear</b>	<b>Veh Spd (mph)</b>	<b>Eng Spd (rpm)</b>	<b>Fuel Econ (mpg)</b>	<b>Grade (%)</b>	<b>Notes</b>
LEVEL ROAD MAXIMUM SPEED	5L	69.6	2677	5.94	0.00	
HI GEAR SPEED @ RATED RPM	5L	67.6	2600	6.07	0.67	
55.0 MPH STEADY-STATE	5L	55.0	2117	7.44	2.37	- Calculated Grade Ability/Fuel Economy

VEHICLE ORDER CODING ERRORS MAY RESULT IF THE "LEVEL ROAD MAX SPEED" VALUE EXCEEDS THE "HI GEAR SPEED @ RATED RPM" AND IS USED AS THE ENGINE PROGRAMMABLE VEHICLE SPEED LIMIT.

IDLE FUEL RATE : 0.65 GALS/HR @ 700 RPM

TORQUE CONVERTER: TC-411 STALL RATIO: 2.71

IF THE RESULTS CONTAIN "----" , VEHICLE CANNOT ATTAIN THAT SPEED.

IF THE RESULTS CONTAIN "\*\*\*\*\*", THE ENGINE USED DOES NOT HAVE A FUEL MAP. FUEL ECONOMY CANNOT BE PREDICTED.

**FUEL ECONOMY**

**Fuel Economy Route: Normal Route - City, Suburban, and Highway**

<b>Key Fuel Economy Information</b>	<b>City</b>	<b>Suburban</b>	<b>Highway</b>	<b>Notes</b>
MILES PER GALLON	6.36	7.99	7.24	
AVERAGE MPH	18.98	39.84	54.61	
MISSION MINUTES	29.8	52.0	173.3	

IF THE RESULTS CONTAIN "\*\*\*\*\*", THE ENGINE USED DOES NOT HAVE A FUEL MAP. FUEL ECONOMY CANNOT BE PREDICTED.

**INTERNATIONAL®****Performance TCAPE Summary  
2007 4300 SBA 4X2 (MA025)****February 09, 2006****GRADEABILITY PERFORMANCE****Enroute - Full Throttle Upshift Performance**

<b>Gear</b>	<b>Trans Ratio</b>	<b>Veh Spd (mph)</b>	<b>Eng Spd (rpm)</b>	<b>Whl Pwr (hp)</b>	<b>Grade (%)</b>	<b>Warn Notes Msg</b>
1C	3.49	0.0	2493.8	0.0	42.40	@ STALL
		5.4	2450.0	157.0	34.10	70% EFF
		7.6	2459.7	173.0	26.10	80% EFF
		10.2	2498.4	178.5	19.60	
2C	1.86	10.2	2450.0	157.8	17.20	
		19.0	2497.5	179.6	10.00	
2L	1.86	19.0	1815.4	189.3	10.60	
		25.9	2470.1	213.6	8.50	
3L	1.41	25.9	1872.5	194.8	7.60	
		30.4	2200.0	217.6	7.10	
		34.6	2501.3	211.6	5.80	
4L	1.00	34.6	1774.0	184.2	4.90	
		42.9	2200.0	216.7	4.30	
		49.2	2525.0	208.3	3.10	
5L	0.75	49.2	1893.8	191.7	2.70	
		57.2	2200.0	211.0	2.10	
		65.5	2521.9	201.7	1.00	
		67.6	2600.0	194.9	0.70	RATED RPM
		68.2	2626.6	188.9	0.50	
		69.6	2677.0	166.8	0.00	LEVEL ROAD

**STARTING / TOP GEAR PERFORMANCE**

<b>Gear</b>	<b>Trans Ratio</b>	<b>Veh Spd (mph)</b>	<b>Eng Spd (rpm)</b>	<b>Whl Pwr (hp)</b>	<b>Grade (%)</b>	<b>Warn Notes Msg</b>
1C	3.49	0.0		0.0	42.40	@ STALL
		7.6		173.0	26.10	80% EFF - Calculated Start Ability

@ - WHEELSLIP CAN OCCUR AT THE GRADE SHOWN. THE VEHICLE IS CAPABLE OF INCREASED GRADEABILITY IF MORE WEIGHT IS PLACED ON THE DRIVE AXLES.

THE TRANSMISSION WAS SIMULATED IN PERFORMANCE OPERATING MODE.

**ACCELERATION PERFORMANCE RESULTS**

**Acceleration Performance Grid**

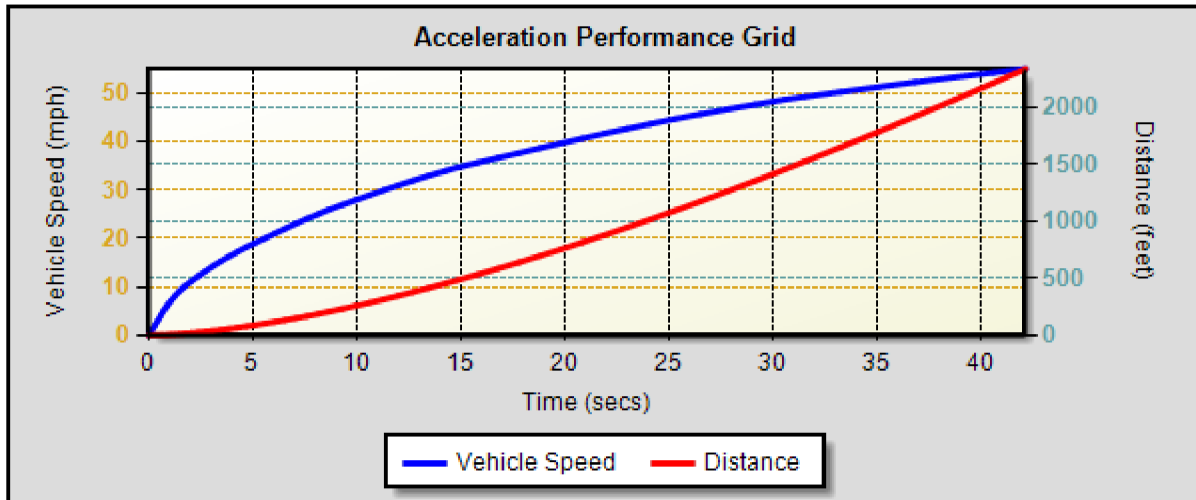

Acceleration Performance: TIME TO ACCELERATE ON A 0.00% GRADE TO 55.0 (MPH) IS 42.20 (SECS)

**Acceleration Performance Details**

Gear	Time (secs)	Distance (feet)	Speed (mph)	Notes
1	0.15	0.1	1.0	
	0.30	0.4	2.0	
	0.44	1.0	3.0	
	0.58	1.7	4.0	
	0.72	2.6	5.0	
	0.88	3.9	6.0	
	1.05	5.6	7.0	
	1.25	7.7	8.0	
	1.47	10.5	9.0	
	1.72	13.9	10.0	
2	1.77	14.6	10.2	
	2.08	19.5	11.2	
	2.40	25.0	12.2	
	2.73	31.1	13.2	
	3.08	38.2	14.2	
	3.45	46.2	15.2	
	3.85	55.3	16.2	
	4.27	65.5	17.2	
3	4.71	77.0	18.2	
	5.11	88.0	19.0	
	5.60	101.8	20.0	
	6.08	116.5	21.0	
	6.57	132.0	22.0	
	7.08	148.7	23.0	
	7.61	166.9	24.0	
4	8.17	187.0	25.0	
	8.67	205.9	25.9	
	9.32	230.9	26.9	
	9.97	257.0	27.9	
	10.63	284.3	28.9	
	11.30	313.3	29.9	
	11.99	344.2	30.9	

**INTERNATIONAL®****Performance TCAPE Summary  
2007 4300 SBA 4X2 (MA025)****February 09, 2006**

<b>Gear</b>	<b>Time (secs)</b>	<b>Distance (feet)</b>	<b>Speed (mph)</b>	<b>Notes</b>
	12.72	377.5	31.9	
	13.47	413.5	32.9	
	14.27	452.5	33.9	
5	14.85	481.7	34.6	
	15.83	532.3	35.6	
	16.82	584.6	36.6	
	17.82	638.7	37.6	
	18.82	694.8	38.6	
	19.84	752.9	39.6	
	20.87	813.4	40.6	
	21.92	876.9	41.6	
	23.01	943.9	42.6	
	24.13	1014.8	43.6	
	25.30	1090.6	44.6	
	26.53	1171.7	45.6	
	27.81	1258.6	46.6	
	29.17	1351.9	47.6	
	30.59	1452.6	48.6	
6	31.56	1521.9	49.2	
	33.30	1649.0	50.2	
	35.08	1780.8	51.2	
	36.88	1917.8	52.2	
	38.73	2060.9	53.2	
	40.64	2211.2	54.2	
	42.20	2336.2	55.0	

**INTERNATIONAL®****Performance TCAPE Summary  
2007 4300 SBA 4X2 (MA025)****February 09, 2006****REQUIRED TCAPE INFORMATION****TCAPE Factors For Vehicle**

Selected Rear Axle Gear Ratio(s):	6.17
Vehicle Vocation:	GENERAL ON HIGHWAY
Road Surface Type:	TYPICAL
Enroute PTO:	NO
Transmission Mode:	Performance
Fuel Economy Route:	Normal Route - City, Suburban, and Highway
ID Wheel Slip Conditions:	Yes
Engine Fan Type:	VISCOUS
Parked PTO:	NO
Road Governor/Cruise Ctrl:	No
Acceleration Grade (%):	0.0
Alternator (A):	40
Frontal Area (FT2):	96
Air Compressor (HP):	2.20
Vehicle Height (IN):	144
Steering Gear (HP):	2.60
Air Conditioner (HP):	3.20
Weight on Drive Axle (LBF):	20000
Acceleration Vehicle Spd (MPH):	55.0
Speed Limit on Route (MPH):	61.0
Vehicle Width (IN):	96
Relative Drag Coefficient:	85
TIRE, FRONT	2 - RADIAL NORMAL
TIRE, REAR	4 - RADIAL NORMAL

**Components**

0002AGV	AXLE, FRONT NON-DRIVING {Dana Spicer I-130S} I-Beam Type, 13,000-lb Capacity
0004SBC	AIR COMPRESSOR {Bendix Tu-Flo 550} 13.2 CFM Capacity
0005PSA	STEERING GEAR {Sheppard M-100} Power
0008GEJ	ALTERNATOR {Leece-Neville 8LHP2172VAH} Brush Type; 12 Volt 110 Amp. Capacity, Pad Mounted
0012NPP	ENGINE, DIESEL {International DT466} 50 State, 245 HP, 620 lb-ft Torque @ 1400 RPM, 2600 RPM Governed Speed, # 2 Bell Housing
0012TSY	FAN DRIVE {Borg-Warner SA85} Viscous Screw On Type
0013AJE	TRANSMISSION, AUTOMATIC {ALLISON 3000_RDS_P} 4th Generation Controls; Close Ratio, 5-Speed, With Overdrive; On/Off Hwy; Includes Oil Level Sensor, With PTO Provision, Less Retarder, With 80,000-lb GVW & GCW Max.
0014AGY	AXLE, REAR, SINGLE {Dana Spicer 21060S} Single Reduction, 20,000-lb Capacity, 190 Wheel Ends
0016030	CAB Conventional, Steel
0016WKB	AIR CONDITIONER {International Blend-Air} With Integral Heater & Defroster
07372130116	TIRE, REAR 11R22.5 G164 RTD M+S (GOODYEAR) 499 rev/mile, load range G, 14 ply 11R22.5 G164 RTD M+S (GOODYEAR) 499 rev/mile, load range G, 14 ply
07382130155	TIRE, FRONT 11R22.5 G149 RSA (GOODYEAR) 501 rev/mile, load range H, 16 ply 11R22.5 G149 RSA (GOODYEAR) 501 rev/mile, load range H, 16 ply

**TCAPE HAS BEEN DESIGNED TO GIVE ECONOMY AND PERFORMANCE PREDICTIONS WHICH HAVE BEEN SHOWN TO BE TYPICAL FOR MOST OPERATIONS. HOWEVER, DUE TO OPERATING CONDITIONS, DRIVER INFLUENCES, AND OTHER FACTORS, YOUR RESULTS MAY VARY FROM THOSE PREDICTED. ALSO, BECAUSE OF FUEL MAPPING PROCEDURES USED BY VARIOUS ENGINE MANUFACTURERS, COMPARISONS OF FUEL ECONOMY RESULTS FOR DIFFERENT BRANDS OF ENGINES MAY VARY FROM THOSE SHOWN.**

**INTERNATIONAL TRUCK AND ENGINE CORPORATION SHALL NOT BE LIABLE FOR ANY LOSS OF PROFITS, LOSS OF USE, INTERRUPTION OF BUSINESS OR INDIRECT, SPECIAL, INCIDENTAL OR CONSEQUENTIAL DAMAGES OF ANY KIND THAT ARE INCURRED BY DEALER OR BY DEALER'S CUSTOMERS AS A RESULT OF RELIANCE ON TCAPE, WHETHER THE CLAIM IS IN CONTRACT, TORT (INCLUDING NEGLIGENCE), STRICT LIABILITY OR OTHERWISE.**

**Weight Summary**  
**2007 4300 SBA 4X2 (MA025)**

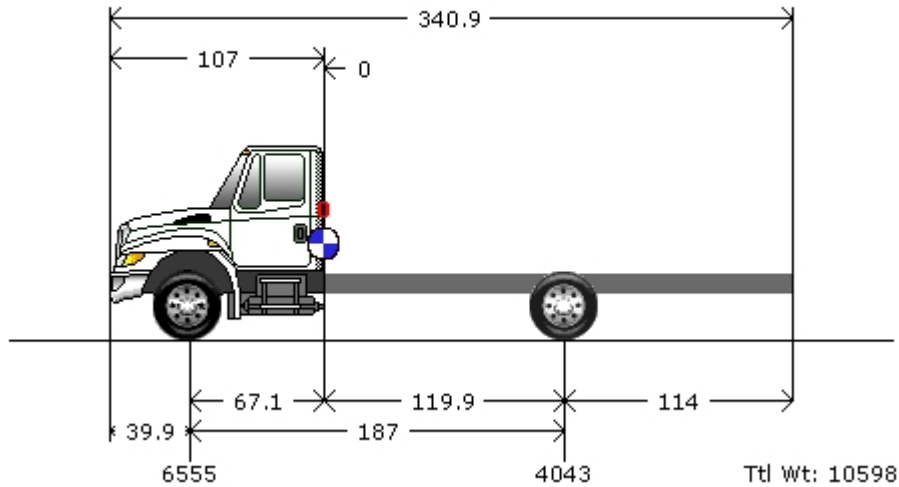

Graphics are provided as visual aids only and are not intended to represent the actual scale, shape, or color of the truck or its components. All weights are represented in lbs.

Truck			Body/Trailer			Chassis/Empty Weights	
Bumper to Axle	(BA)	39.9	Body Length	(BL)	N/A	Tractor Front Axle:	6,555
Wheelbase	(WB)	187.0				Tractor Rear Axle:	4,043
Axle to Frame	(AF)	114.0					
Axle to Back Cab	(ABC)	67.1					
Cab to Axle	(CA)	119.9					
Usable Cab to Axle		119.9					
CA Reduction Adjustment		0					
Fuel (Gals)		0					

Before the Cab			Cab			Payloads Chassis			Body			After the Body		
#	Weight	CG	#	Weight	CG	#	Weight	CG	#	Weight	CG	#	Weight	CG
						1	0	0						

Loads	
Payload Weight:	0
Driver:	0
Fuel(lbs):	0

Weight Distribution	
Total Front Axle:	6,555
Total Rear Axle:	4,043
Total Weight:	10,598

Weights and clearances in this proposal are estimates only. International is not liable for any consequences resulting from any differences between the estimated weights and clearances and the actual manufactured weights and clearances.



**INTERNATIONAL®****Weight Summary**  
**2007 4300 SBA 4X2 (MA025)****February 09, 2006****Weight Distribution**

All weights are represented in lbs.

	<u>Truck</u>		
	Front	Rear	Total
<b><u>Chassis Weight</u></b>			
Chassis Weight:	6,555	4,043	<b>10,598</b>
Fuel:	0	0	<b>0</b>
<b>(Curb Weight):</b>	<b>6,555</b>	<b>4,043</b>	<b>10,598</b>

**Loads**

Payloads:	0	0	<b>0</b>
Driver:	0	0	<b>0</b>
<b>Axle Totals (Gross Weight):</b>	<b>6,555</b>	<b>4,043</b>	<b>10,598</b>

**Weight Ratings**

	<u>Truck</u>	
	Front	Rear
Axle(axle capacity)	13,000	20,000
Tire(tire capacity)	13,220	26,440
Suspension(suspension capacity)	13,000	23,500
Spring:	0	
Fed Bridge Law (axle spread):	20,000	20,000
<b>Wheel Combination</b>	<b>Load</b>	<b>Limit</b>
1 - 2	10,598	45,000

Federal Total Vehicle Weight Limit: 80,000

Maximum Gross Vehicle Weight Rating (GVWR) 33,000 - Gross Vehicle Weight(GVW) 10,598 = 22,402 Reserves

**Weight Summary**

\* Distributed weights are within capacity limits

**Turning Radius Summary**  
**2007 4300 SBA 4X2 (MA025)**

**February 09, 2006**

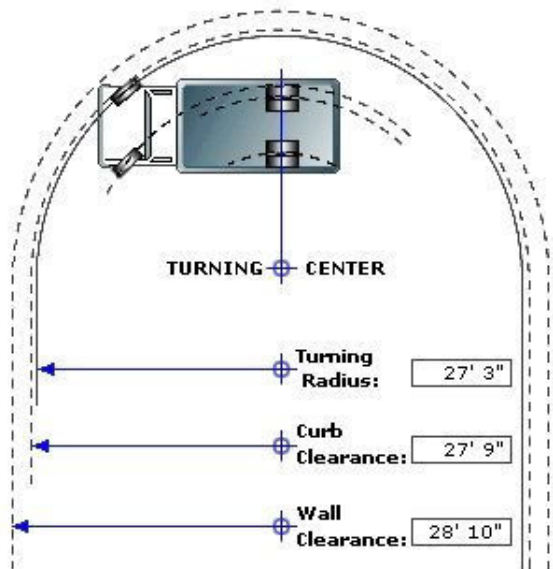

Series: 4000  
Model: MA025  
Description: 4300 SBA 4X2  
Model Year: 2007

**Calculation Factors**

Wheelbase: 187  
Front Axle: 0002AGV  
Description: AXLE, FRONT NON-DRIVING, {Dana Spicer I-130S} I-Beam Type, 13,000-lb Capacity  
Front Wheel: 0027DMA  
Description: WHEELS, FRONT, DISC; 22.5" Painted Steel, 2 Hand Hole, 10 Stud (285.75MM BC) Hub Piloted, Flanged Nut, Metric Mount, 8.25 DC Rims; With Steel Hubs.  
Front Tire: 07382130155  
Description: TIRES, 11R22.5 G149 RSA (GOODYEAR) 501 rev/mile, load range H, 16 ply  
Steering Gear: 0005PSA  
Description: STEERING GEAR, {Sheppard M-100} Power

**Turning Radius Statistics**

General Information

Inside Turn Angle: 45 Degrees  
Radial Overhang: 19

Axle Information

KingPin Inclination: 7.5 Degrees  
KingPin Center: 69.12

**Turning Radius - Curb View**

C - Curb Contact Length: 15.91  
CI - Curb Clearance Increment: 5.78  
CR - Curb Clearance Radius: 27'9"  
CH - Curb Height: 6"  
TR - Turning Radius: 27'3"  
TW - Tire Width: 10.80

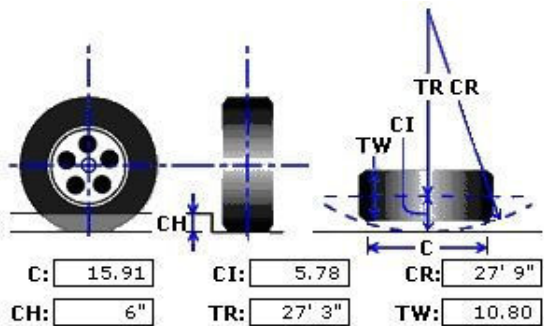

\* All Measurements are in inches, unless otherwise specified.

This information is based on engineering information available at this time. Actual figures may vary. International Truck and Engine Corporation cannot accept liability for consequences due to this variance.



**Altec Industries, Inc.**

**Building Division**

**Customer:**

City of Monroe  
215 N. Broad St.  
PO Box 725  
Monroe, GA 30655

**Ship To:**

**Building Work Order Number: SO#. 652658**  
**Selling Work Order Number: DJ#. 60-7589211**

**Account Manager: Tim Luker**  
**Inside Sales Representative: Ivan Whitfield**  
**Quote Number: 58806**

<u>Item</u>	<u>Quantity</u>	<u>Description</u>	<u>Price</u>
-------------	-----------------	--------------------	--------------

UNIT

1.	1	ALTEC Model <b>DM47</b> Hydraulic Derrick, <b>Rear mount</b> , designed for mounting over rear axle with a <b>Turntable winch</b> , built in accordance with ALTEC'S standard specifications and to include the following features:	
----	---	---	--

Maximum Sheave Height 46.4 ft

Maximum Horizontal Reach 37.0 ft

Maximum Digging Radius 26.7 ft

Elevation - From 80 degrees above horizontal to 20 degrees below horizontal

Performance Ranges per the attached capacity chart.

- A. Unit meets or exceeds ANSI 10.31-1995. Unit serial number placard clearly states compliance.
- B. Unit is designed and manufactured in facilities that are certified to meet ISO 9001 requirements.
- C. Winch: 15,000 pound bare drum capacity turntable winch with 8.625" diameter drum to comply with ANSI 10.31 Section 4.10.4 for synthetic rope or 15,000 pound bare drum capacity boom tip winch. High torque hydraulic motor drives a self-locking worm gear winch. Counterbalance valves on motor

Work Order Number: **SO# 652493, 645, 646, 647, 649, 651, 653, 654, 655, 658, 660, 661, 663, 665, 667, 670, 672, 674, 678, 680, 682, 856, 858**

Altec Model: **DM47-TR Riding Seat, Uppers, Platform, Line Body**

<u>Item</u>	<u>Quantity</u>	<u>Description</u>	<u>Price</u>
		provide reliable load holding	
		D. Insulated, "46 kV and below"	
		E. Hydraulic Overload Protection System – activates when unit is exposed to overload condition. System prevents actuation of all functions that could add to the overload condition including: <ul style="list-style-type: none"><li>- Boom Lower</li><li>- Intermediate Boom Extend</li><li>- Third Stage Boom Extend</li><li>- Winch Raise</li><li>- Auger Dig</li></ul> System automatically resets when overload condition is relieved.	
		F. Hydraulic Side Load Protection relieves overload conditions by allowing rotation system to back drive.	
		G. System pressure gauges on all vehicle mounted main control stations.	
		H. Transferable Boom Flares include <b>adjustable alignment guides</b> .	
		I. Pole Guides – cylinder driven open/close and tilt <b>includes double pilot operated check valves</b> to support poles in both tilt directions. Also includes <b>tilt interlock</b> that prevents the upper boom from extending when the transferable flares are attached to the intermediate boom until the guides are articulated to the full up position.	
		J. Fiberglass Boom Tip with provisions for platform attachment.	
		K. Two-part load line attachment point on intermediate boom.	
		L. Full capacity fiberglass upper boom is round and is fabricated using a Centrifically Cast process that provides a smooth surface finish inside and out that is easy to clean and is highly resistant to damage.	
		M. Cylinders: Rods are chrome plated and ends are threaded and welded.	
		N. Bearings: Lift cylinder equipped with self-aligning bearings.	

Work Order Number: **SO# 652493, 645, 646, 647, 649, 651, 653, 654, 655, 658, 660, 661, 663, 665, 667, 670, 672, 674, 678, 680, 682, 856, 858**

Altec Model: **DM47-TR Riding Seat, Uppers, Platform, Line Body**

<u>Item</u>	<u>Quantity</u>	<u>Description</u>	<u>Price</u>
-------------	-----------------	--------------------	--------------

All extending booms utilize **slide bearings**; there are **no roller bearings** on extending booms.

- O. Proportional-Hydraulic Control System: The electrical control panel(s) and pilot hydraulic system provide easy to operate controls with superior metering. There are only **two hydraulic lines through rotation**. Hydraulic control valves for Rotation, Boom Elevation, Boom Extension, Digger and Winch are pilot operated and controlled by a proportional pilot system which provides full metering and feathering characteristics. There are **no hydraulic lines within operator control station**.
- P. Control system includes **single quick connect plug** for quick and easy installation of radio remote control system in the field upon request.
- Q. Standard/Low Speed Selector allows an operator to select standard or low functional speeds without respect to engine throttle. When in standard mode, each function operates at normal speeds. When in low mode, the maximum operational speed of each function is approximately half that of the standard speed, providing a more meterable feel. The function is separate from engine throttle control, giving the operator additional fine tuning speed control.
- R. Hydraulic Dump Valve installed in pedestal: Provides extra protection by **diverting hydraulic flow away from the main control valve when unit is idle**. Dump valve solenoid is electronically activated when a function is operated.
- S. Boom Storage Protection System – switch on main boom activates hydraulic overload protection system to prevent operator from inadvertently placing excessive down force on boom stow bracket.
- T. Continuous rotation including worm drive rotation gearbox. With booms horizontal and fully extended, unit is able to rotate a 500 lbs load on winch line at boom tip up a 5 degree slope.
- U. Manual Override of Hydraulic Functions at main control valve.
- V. Complete Hydraulic System including:

Work Order Number: SO# 652493, 645, 646, 647, 649, 651, 653, 654, 655, 658, 660, 661, 663, 665, 667, 670, 672, 674, 678, 680, 682, 856, 858

Altec Model: DM47-TR Riding Seat, Uppers, Platform, Line Body

<u>Item</u>	<u>Quantity</u>	<u>Description</u>	<u>Price</u>
		<ol style="list-style-type: none"> <li>1. Magnetic suction separator</li> <li>2. Return line filter with cold oil indicator</li> <li>3. Hydraulic pressure gauges</li> </ol>	
		W. Outrigger/Boom Interlock System: Helps prevent operator from using unit until all outriggers are lowered.	
		X. Outrigger/Unit Selector Control: Located near the outrigger controls, allows operator to divert hydraulic oil from machine circuit for outrigger operation. This reduces the potential for inadvertent outrigger movement during machine operation if outrigger controls are bumped.	
		Y. Outrigger Control Valves, located at tailshelf	
		Z. Outrigger Motion Alarm: Provides audible alarm when any of the outriggers are in motion.	
		AA. Back-up Alarm, installed	
		BB. Preventative Maintenance: Unit owner can select means of tracking maintenance intervals by calendar time or PTO hours. If the owner selects calendar driven cycles, preventative maintenance is required no more frequently than every 6 months. If the owner selects PTO hour driven cycles, preventative maintenance interval is likely to be greater than 6 months. Both programs allow the equipment owner to lower life cycle costs through higher product uptime and lower maintenance costs.	
		CC. Tool outlets at tailshelf – tool control valve is integral to the outrigger control valve on the vehicle curbside.	
		DD. Two (2) Operator's and Maintenance/Parts Manuals	
		EE. Painted white with <b>Altec Powder Coat Paint Process</b> which provides a finish-painted surface that is highly resistant to chipping, scratching, abrasion and corrosion. Paint is electro-statically applied to the <i>inside</i> as well as outside of all fabricated parts then high temperature cured prior to assembly ensuring maximum coverage and protection.	
2.	1	#005 Rear Mount pedestal.	
3.	1	#008 Turntable Winch	

**Work Order Number: SO# 652493, 645, 646, 647, 649, 651, 653, 654, 655, 658, 660, 661, 663, 665, 667, 670, 672, 674, 678, 680, 682, 856, 858**

**Altec Model: DM47-TR Riding Seat, Uppers, Platform, Line Body**

<u>Item</u>	<u>Quantity</u>	<u>Description</u>	<u>Price</u>
4.	1	#011 Winch, normal speed (15,000 pounds)	
5.	1	#176 Platform use or combined Digger Derrick/Platform use.	
6.	1	#168 Rear Mount - Traditional Control Seat, installed on curbside of turntable, includes single control station.	
7.	1	#031 Foot throttle, installed at operators station.	
1.	1	#108 Four-Lever Upper Controls and Tool Circuit, transferable, including power package. Controls include: <ul style="list-style-type: none"> <li>(a) four (4) individual levers, for lift, rotation, sequential extension and winch functions</li> <li>(b) one knob for on/off (blocking valve), including automatic two-speed throttle</li> <li>(c) one knob for on/off of upper tool circuit and engine start/stop</li> </ul>	
8.	1	#088 Digger – right-hand storage – normal.	
9.	1	#94 Digger, Two-Speed Mechanical Shift, 12,000 ft/lb, includes all of the components necessary to operate digger, installed. Planetary gear drive producing up to 12,000 ft/lbs. Running torque with 2 ½ inch hex kelly bar.	
10.	1	#041 Outriggers, A-frame, flat shoe, 149 inch maximum spread, for use as auxiliary outriggers only.	
11.	1	#450 Outriggers, A-frame, folding shoe, 153 inch maximum spread, for use as auxiliary or primary outriggers.	
12.	1	#140 Outrigger Interlock System	
14.	1	#501 Power Distribution Module, shipped loose. The Power Distribution Module is a compact self-contained electronic system that provides a standardized interface with the chassis electrical system. The Power Distribution Module (PDM) is composed of a main board, approximately 12.0 x 13.0 inches (305 x 330 mm), designed to be mounted behind the driver's seat, inside the cab. Additional modules plug in to accommodate	

**Work Order Number: SO# 652493, 645, 646, 647, 649, 651, 653, 654, 655, 658, 660, 661, 663, 665, 667, 670, 672, 674, 678, 680, 682, 856, 858**

**Altec Model: DM47-TR Riding Seat, Uppers, Platform, Line Body**

<u>Item</u>	<u>Quantity</u>	<u>Description</u>	<u>Price</u>
-------------	-----------------	--------------------	--------------

various options such as engine start/stop, variable throttle control, power take off, interface with Allison World transmission, and engine speed control module for specific engines and chassis. In addition to the above potential options, the PDM also provides up to 16 accessory circuits to be used for controlling other customer specified electrical components. The PDM includes built in test capabilities and diagnostic input, output and status LED's to quickly assess the PDM's performance. All components are circuit board mounted to facilitate replacement and reduce repair time should it be required.

The PDM provides benefits to the customer by providing a standardized, centrally located box that greatly reduces troubleshooting time when evaluating ancillary electrical system malfunctions, thereby reducing maintenance costs, shipped loose.

- |     |   |   |  |
|-----|---|---|--|
| 15. | 1 | #77 Reservoir Assembly - includes 60 gallon reservoir, filter and magnetic suction separator.                                   |  |
| 16. | 1 | #145 Platform, fiberglass pin-on, 24 x 24 x 42 inches, nominal, with interior /exterior platform access step, 300 lb. capacity. |  |
| 17. | 1 | #150 Platform Cover, for single, one-man, side-mounted fiberglass platform, nylon-reinforced vinyl, 24 x 24 inches.             |  |
| 18. | 1 | #153 Platform Liner, for single, one-man, side-mounted fiberglass platform, 24 x 24 x 42 inches. Rated at 50 kV.                |  |

**UNIT AND HYDRAULIC ACCESSORIES**

- |     |   |  |  |
|-----|---|--|--|
| 19. | 1 | Primary outriggers are to be installed at rear behind rear axle. Auxiliary outriggers are to be installed between back of cab and front of body. |  |
| 20. | 1 | All outrigger controls to be located at rear corners of vehicle to provide visibility of outriggers by operator.                                 |  |
| 21. | 1 | Hydraulic oil reservoir to be installed in front of cargo area.  |  |
| 22. | 1 | Hydraulic oil and lubricants installed.  |  |



Work Order Number: **SO# 652493, 645, 646, 647, 649, 651, 653, 654, 655, 658, 660, 661, 663, 665, 667, 670, 672, 674, 678, 680, 682, 856, 858**

Altec Model: **DM47-TR Riding Seat, Uppers, Platform, Line Body**

<u>Item</u>	<u>Quantity</u>	<u>Description</u>	<u>Price</u>
23.	1	Subbase assembly for mounting of derrick pedestal and outriggers, to consist of 6 inch x 4 inch tubing (3/8 inch wall) each side of chassis frame with top and bottom plate.	
24.	1	ALTEC 18 inch diameter auger, full flight with Pengo boring head, and 2 ½ inch hex.	
25.	1	8-1/2 foot nylon rope auger wind up strap.	
26.	2	Fall arrest system, includes one (1) extra large body harness (jacket size 44-52) and six foot decelerating type lanyard.	
27.	1	DM Long Tool Storage in Rear Pedestal	
28.	1	Wheel chocks, pair, rubber, 10 x 9 x 5 ¾ inches.	
29.	1	Synthetic braided winch line rope, with eye in each end, 1 inch diameter, 115 ft. long, rated at 12,000 lbs.	
30.	1	Winch load line swivel hook, 8 ½ ton.	
31.	1	Adjustable Boom storage support with strobe light brackets, installed.	
32.	1	Pump, tandem, mounted to Power Take-off	
33.	1	Cab controlled heavy-duty SAE power take-off, for use with transmission type determined by chassis selection, installed with indicator light in cab.	
34.	1	Adjustable flow divider, 8 GPM, for use with hose reel.	
	1	Spring rewind hose reel with two (2) 25-foot hydraulic hoses, 3/8 inch pressure line and ½ inch return line. Includes HTMA quick couplings with dust caps.	

**NOTE: Install hose reel at curbside rear, payout to rear.**

**BODY**

35.	1	Bobtail Service Line/Step body, suitable for installing on any dual rear wheel chassis with 120 inch CA dimension	
-----	---	---	--

Work Order Number: **SO# 652493, 645, 646, 647, 649, 651, 653, 654, 655, 658, 660, 661, 663, 665, 667, 670, 672, 674, 678, 680, 682, 856, 858**

Altec Model: **DM47-TR Riding Seat, Uppers, Platform, Line Body**

<u>Item</u>	<u>Quantity</u>	<u>Description</u>	<u>Price</u>
-------------	-----------------	--------------------	--------------

when used in conjunction with a rear mounted derrick. Body is built in accordance with our standard specification including a walk-in step. Reference quote #14-5138.

This application is to use the latest design of the Stock/Global Derrick Body. This includes the 34 inch long tailshelf used in conjunction with the Code-450 outriggers. Tailshelf will include a 3 inch lip on back and sides, drain holes at corners, 3/16 inch light panels.

A. Body: Fabricated from A60 grade 100% zinc alloy coated steel with the following minimum gauge thickness:

1. 16 gauge outside panels
2. 16 gauge top panels
3. 14 gauge end panels
4. 20 gauge inner door panels
5. 20 gauge outer door panels
6. 18 gauge shelving, spangled steel
7. 14 gauge wheel panels
8. 12 gauge safety tread steel floor (four-way pattern)
9. Structural channel crossmembers
10. Wheel chock holders installed one (1) each side of body in fender panel
11. Gripstrut on curbside horizontal and third vertical for access to riding seat
12. Drop-in wooden tailboard at rear of body.
13. Rigid door holders for vertical doors.
14. Four (4) recessed tie-down rings in body floor.

B. Body Dimensions:

1. 142 inch overall body length
2. 93 inch outside width
3. 46 inch body height
4. 18 inch compartment depth
5. 57 inch floor width

C. Compartmentation - Left Side:

1. First Vertical – Three (3) adjustable shelves with removable dividers on 4 inch centers.
2. Second Vertical – Six (6) adjustable locking swivel hooks (1-4-1).
3. Third Vertical – Six (6) adjustable locking swivel hooks

Work Order Number: SO# 652493, 645, 646, 647, 649, 651, 653, 654, 655, 658, 660, 661, 663, 665, 667, 670, 672, 674, 678, 680, 682, 856, 858

Altec Model: DM47-TR Riding Seat, Uppers, Platform, Line Body

<u>Item</u>	<u>Quantity</u>	<u>Description</u>	<u>Price</u>
-------------	-----------------	--------------------	--------------

(1-4-1).

4. Horizontal – One (1) plain fixed shelf.

D. Compartmentation – Right Side:

1. First Vertical - Six (6) adjustable locking swivel hooks (1-4-1).
2. Second Vertical – Access steps to cargo area (gripstrut). Two sloping grab handles, one each side of access steps to meet Altec's access & egress standards. Drop-in wooden board to install at top of access steps. **Provide 12 gauge treadplate scuff panels on each wall of access step area.**
3. Third Vertical - Six (6) adjustable locking swivel hooks (2-2-2).
4. Horizontal – Two (2) fixed shelves with removable dividers on 8" centers.
5. Through Shelf - Full length of left side to rear of body with (2) hotstick brackets and drop down rear door.

A. Standard Features:

1. Basic body fabricated from A60 grade 100% zinc alloy coated steel
2. All doors are full, double paneled, self-sealed with built-in drainage for maximum weather-tightness. Electro-zinc plated, steel hinge rods extend full length of door. Door hinges are zinc alloy material attached with rivets.
3. All doors contain zinc plated flush type, single point paddle type locks with recessed handles, including keyed locks and adjustable two-stage strikers. Door handles are riveted to the outer door panel. Back panel has opening for easy access.
4. Heavy-gauge welded steel base construction with safety tread floor.
5. All edges are either rolled or folded for strength and safety
6. Door header drip rail at top for maximum weather protection.
7. Neoprene fenders on wheel fender panels.
8. Steel treated for extra good primer bond and rust resistance
9. Automotive underseal applied to body.
10. Prime painted with two part epoxy.

Work Order Number: SO# 652493, 645, 646, 647, 649, 651, 653, 654, 655, 658, 660, 661, 663, 665, 667, 670, 672, 674, 678, 680, 682, 856, 858

Altec Model: DM47-TR Riding Seat, Uppers, Platform, Line Body

<u>Item</u>	<u>Quantity</u>	<u>Description</u>	<u>Price</u>
		11. Automotive type non-porous door seals mechanically fastened to the door facing.	
37.	1	Access step installed in cargo area at right side for access to right side compartment.	
38.	1	Master body security locking system.	
<b><u>BODY ACCESSORIES</u></b>			
39.	1	<b>This truck is to have NO access at rear. All access is to be from curbside entry.</b>	
40.	1	Side access step, installed so that the step extends 2" beyond body.	
41.	1	Riding seat access step, installed on curbside compartment top.	
42.	1	Longitudinal through box installed in subbase with drop down door at rear.	
43.	1	Pintle hook, T125 style or equivalent, with frame reinforcement and two safety chain rings installed at 28 inches (+/- 1 inch) from ground to center of eye. Pintle hook to have secondary latching.	
44.	1	One set of splash aprons with Altec Logo installed behind rear wheels.	
45.	1	Triangular reflector kit installed in cab behind seat on passenger's side.	
46.	1	Five-pound fire extinguisher with mounting bracket, installed in streetside first vertical compartment.	
47.	1	Rubber dock bumpers installed on right and left side of frame at rear.	
<b>NOTE: Extend chassis frame to rear to allow dock bumpers to protect pintle hook and glad hand connectors.</b>			
48.	1	Three-point grounding system tying unit, body, and chassis to a common ground with copper "U" bolts	

**Work Order Number: SO# 652493, 645, 646, 647, 649, 651, 653, 654, 655, 658, 660, 661, 663, 665, 667, 670, 672, 674, 678, 680, 682, 856, 858**

**Altec Model: DM47-TR Riding Seat, Uppers, Platform, Line Body**

<u>Item</u>	<u>Quantity</u>	<u>Description</u>	<u>Price</u>
		installed at curbside front and curbside rear of vehicle.	
49.	1	Install glad hand connectors at rear of vehicle. Tractor package to be supplied with chassis.	
50.	4	Outrigger pads, wooden, 24 x 24 x 3 inches.	
51.	4	Outrigger pad holders to accept 24 x 24 x 3 inch wooden pads. Install with pendulum retainers.	

**ELECTRICAL ACCESSORIES**

52.	1	Lights and reflectors in accordance with FMVSS #108 lighting package installed.	
53.	1	Two-speed throttle switch adjacent to outrigger /tool controls.	
54.	1	Relocate chassis supplied trailer receptacle at rear near pintle hook.	
55.	1	Install 6-way trailer plug at rear near pintle hook.	
56.	1	Dual tone electronic back up alarm with outrigger motion alarm, installed.	
57.	2	Amber strobe lights installed, one (1) each side of derrick storage support with master switch and indicator light in cab. Strobe lights are to be visible from the front and rear of the vehicle.	

**FINAL ASSEMBLY**

58.	1	Installation of derrick and subbase assembly	
59.		Miscellaneous hardware and materials required for installation of derrick and derrick accessories.	
60.		Installation of body and accessories	
61.		Paint body White with urethane enamel	
62.		Derrick painted white with the Altec Powder Coat Paint Process which provides a finish-painted surface that is highly	

Work Order Number: SO# 652493, 645, 646, 647, 649, 651, 653, 654, 655, 658, 660, 661, 663, 665, 667, 670, 672, 674, 678, 680, 682, 856, 858

Altec Model: DM47-TR Riding Seat, Uppers, Platform, Line Body

<u>Item</u>	<u>Quantity</u>	<u>Description</u>	<u>Price</u>
-------------	-----------------	--------------------	--------------

resistant to chipping, scratching, abrasion and corrosion. Paint is electro-statically applied to the *inside* as well as outside of fabricated parts then high temperature cured prior to assembly ensuring maximum coverage and protection

- |     |  |  |  |
|-----|--|--|--|
| 63. |  | Safety and instructional signs, installed  |  |
| 64. |  | Vehicle height placard is to be placed in view of driver   |  |
| 65. |  | Shield exhaust from hydraulic hoses.   |  |
| 66. |  | All walk surfaces, cargo area, access steps, compartment tops, etc... are to be painted with black non-skid paint. |  |

**MISCELLANEOUS**

- |     |  |   |  |
|-----|--|---|--|
| 67. |  | This derrick is designed and manufactured in a facility that is certified to meet ISO 9001  |  |
| 68. |  | One (1) year parts warranty   |  |
| 69. |  | Ninety (90) days warranty for travel charges  |  |
| 70. |  | One (1) year labor warranty   |  |
| 71. |  | For so long as the initial purchaser owns the product, major components warranty at an Altec service facility (See Altec Limited Warranty)  |  |
| 72. |  | Bidder to supply a self-directed, computer based training (CBT) program. This program will provide basic instruction in the safe operation of this aerial device. This program will also include and explain ANSI and OSHA requirements related to the proper use and operation of this unit. |  |

**CHASSIS**

*Reference Proposal # 15394-1*

- |     |   |  |  |
|-----|---|--|--|
| 73. | 1 | 2007 4x2 4300 cab & chassis<br><i>Reference chassis spec for complete chassis info</i> |  |
|-----|---|--|--|

<b>TOTAL</b>			<b>\$144,850.00</b>
--------------	--	--	---------------------

Work Order Number: SO# 652493, 645, 646, 647, 649, 651, 653, 654, 655, 658, 660, 661, 663, 665, 667, 670, 672, 674, 678, 680, 682, 856, 858

Altec Model: DM47-TR Riding Seat, Uppers, Platform, Line Body

<u>Item</u>	<u>Quantity</u>	<u>Description</u>	<u>Price</u>
<b><u>Additional Options</u></b>			
1.	1	Two capacity pole rack, streetside, ratchet tie downs front & rear, rear rack removable	\$734
2.	1	four (4) tie down rings. 2 in rear floor and 2 near top of rear outrigger legs	\$88
3.	1	locking dog assembly complete with kelly bar adapter & drive end wrench	\$1408
4.	1	two (2) post mounted spot lights, one on each side of cab	\$235 each
5.	1	compartment lights, single type, each with on/off switch and master in cab.	\$477
6.	1	Fairmont H4802 hydraulic tamp (altec part #8930-00400)	\$1311
7.	1	Fairmont HRD-58 ground rod driver (altec part # 9000-11192)	\$2159
8.	1	Braden PD18B-11FEB Front Mounted Winch with heavy duty Braden Universal Bumper: <ul style="list-style-type: none"> <li>▪ 20,000 pounds capacity</li> <li>▪ Extended shaft to right side</li> <li>▪ Extend front bumper and cover with treadplate</li> <li>▪ Installation</li> <li>▪ Hydraulic drive assembly for front winch, including: <ul style="list-style-type: none"> <li>Two-speed hydraulic motor</li> <li>Control valve assembly in cab</li> <li>Hydraulic hoses and fittings</li> </ul> </li> <li>▪ Installation including controls for winch forward/reverse</li> <li>▪ Rated in compliance with SAE J706 JUL85</li> <li>▪ Extension shaft speed is more than 4 times drum speed</li> <li>▪ 11 inch drum width</li> <li>▪ 13 inch flange diameter</li> </ul>	\$7701
<b>Grand Total for all Options</b>			<b>\$14,348</b>

Work Order Number: **SO# 652493, 645, 646, 647, 649, 651, 653, 654, 655, 658, 660, 661, 663, 665, 667, 670, 672, 674, 678, 680, 682, 856, 858**

Altec Model: **DM47-TR Riding Seat, Uppers, Platform, Line Body**

<u>Item</u>	<u>Quantity</u>	<u>Description</u>	<u>Price</u>
-------------	-----------------	--------------------	--------------

**NOTES:**

1. *F.O.B. – Duluth, MN*
2. Price does not reflect any local, state or Federal Excise Taxes (F.E.T). All appropriate taxes will be added to the final price in accordance with regulations in effect at time of invoicing.

**Changes made to this order may affect whether or not this vehicle is subject to F.E.T. A review will be made at the time of invoicing and any applicable F.E.T. will be added to the invoice amount.**

3. Terms: If chassis is ordered through Altec Industries, Inc. the chassis payment is due upon receipt of the chassis at Altec Industries, Inc. Balance is due net ten (10) days after receipt of completed unit.
4. Interest charge of ½% per month to be added for late payment.
5. **Trade-in offer is conditional upon equipment being maintained to DOT (Department of Transportation) operating and safety standards. This will include, but not limited to tires, lights, brakes, glass, etc. All equipment, i.e., jibs, winches, pintle hoods, trailer connectors, etc., and are to remain with unit unless otherwise agreed upon in writing by both parties. Altec Industries reserves the right to re-negotiate its trade-in offer if these conditions are not met.**

**All reasonable and necessary expenses required of Altec Industries to execute transportation of the trade-in will be invoiced to the customer for payment if these conditions are not met to maintain DOT standards.**

**Customer may exercise the option to rescind this agreement in writing within sixty (60) days after receipt of purchase order. After that time Altec Industries will expect receipt of trade-in vehicle**



Work Order Number: SO# 652493, 645, 646, 647, 649, 651, 653, 654, 655, 658, 660, 661, 663, 665, 667, 670, 672, 674, 678, 680, 682, 856, 858

Altec Model: DM47-TR Riding Seat, Uppers, Platform, Line Body

<u>Item</u>	<u>Quantity</u>	<u>Description</u>	<u>Price</u>
-------------	-----------------	--------------------	--------------

**upon delivery of new equipment as part of the terms of the purchase order unless other arrangements have been made.**

6. On customer supplied chassis, the chassis will be inspected upon receipt by Altec. Any chassis mounted components including, but not limited to fuel tanks, air tanks, battery boxes, and exhaust systems that have to be relocated in order to properly install equipment will be brought to the customer's attention at the time of discovery and invoiced at the time of completion of the unit.
7. After the initial warranty period, Altec Industries, Inc. offers mobile service units, in-shop service and same day parts shipments on most parts from service locations nationwide at an additional competitive labor and parts rate.



## Utility Committee Meeting

### AGENDA

August 7, 2007

---

**Item:**

Purchase - RTX450 Trencher

**Department:**

Electric and Telecommunications

**Additional Information:**

Vermer has released a new trencher that runs on tracks. It will allow us to work in areas that we could not in the past. The under carriage is a proven unit that is produced by a partner of Caterpillar.

**Financial Impact:****Budgeted Item:****Recommendation / Request:**

Viewing Attachments Requires Adobe Acrobat. [Click here](#) to download.

Attachments / click to download

[Purchase of RTX450 Trencher](#)

**Vermeer Southeast Sales & Service**

1320 Gresham Road  
Marietta, Georgia 30062  
Wes Muschara  
Office: 770.973.8811  
Mobile: 404.557.7279



18-Jul-07

Proposal #014000

To: Brian Thompson  
From: Wes Muschara  
RE: Proposal for Vermeer RTX450 Trencher

We are pleased to provide the following proposal on the Vermeer RTX450 tractor:

**New Vermeer RTX450 Tractor equipped with:**

- Deutz Diesel Oil cooled 50 horsepower (rubber mounted)
- High Temp Shutdown System
- Servo-Controlled Ground Drive Pump – Optimum Operator Control
- 7-spool valve

**Model SFTR450 Sliding Offset Flex Trencher Attachment**

- 60,000 Pound Digging Chain
- 48" Depth Boom with Greasable End Roller
- 48" Restraint Bar
- 8 1/2" Diameter End Roller
- 6" cut Georgia Tiger Cup Combo chain

**B450 Backhoe**

- Backhoe remote controls (blade lift, remote start/stop, creep)
- 12" bucket

City of Monroe Investment:         \$65,520.00        

One year or one thousand hours parts and "in-shop" labor warranty  
Thanks again for partnering with Vermeer Southeast for your equipment needs



## Utility Committee Meeting

### AGENDA

August 7, 2007

---

**Item:**

Purchase of Backup System for Billing Data

**Department:**

Electric and Telecommunications

**Additional Information:**

The new billing system and all other systems need an off site back up. This project would provide that.

**Financial Impact:**

**Budgeted Item:**

**Recommendation / Request:**

Viewing Attachments Requires Adobe Acrobat. [Click here](#) to download.

Attachments / click to download

[Backup Equipment](#)

---

**From:** Brian Thompson  
**Sent:** Tuesday, July 31, 2007 2:21 PM  
**To:** Sharon Griffin  
**Subject:** Purchase off site back-up

**From:** Michael McGuire  
**Sent:** Tuesday, July 31, 2007 11:28 AM  
**To:** Brian Thompson  
**Cc:** 'bkt@monroeutilities.net'  
**Subject:** FW: DR site and upgrading whats in the office now

**From:** Danny Falin [mailto:Danny@GeorgiaITConsulting.com]  
**Sent:** Wednesday, June 06, 2007 12:35 AM  
**To:** Brian Thompson  
**Cc:** Renee Prather; Michael McGuire  
**Subject:** DR site and upgrading whats in the office now

Brian,

We will start 1<sup>st</sup> with the DR site. My recommendation is to setup a larger NAS box there that will hold “everything” in the city hall. You have choices to make on HDD size. Below is the same NAS boxes except different storage. Remember on RAID 5 you lose 1 drive, so if you have 5 500GB drives, you will have 2000GB of space, not 2500GB. Also attaching to both is another UPS rack mount 3000 series, same as in hall now.

<b>Base Unit:</b>	Dual Core Xeon Processor 5050,2x2MB Cache, 3.00GHz, 667MHz FSB, PE 2950 (222-2703)
<b>Processor:</b>	Dual Core Xeon 2nd Processor 5050, 2x2MB Cache, 3.00GHz, 667MHz FSB, PE 2950 (311-6085)
<b>Memory:</b>	2GB 667MHz (4X512MB), Single Ranked DIMMs (311-6153)
<b>Keyboard:</b>	No Keyboard Selected (310-5017)
<b>Video Card:</b>	Broadcom TCP/IP Offload EngineNot Enabled (430-1765)
<b>Video Memory:</b>	Riser with 2 PCI-X Slots (3 Volts) and 1 PCIe Slot for PowerEdge 2950 (320-4608)
<b>Hard Drive:</b>	146GB, SAS, 3.5-inch 10K RPM Hard Drive (341-3030)
<b>Hard Drive Controller:</b>	PERC 5/i, x6 Backplane Integrated Controller Card (341-3066)
<b>Floppy Disk Drive:</b>	No Floppy Drive for x6 Backplane (341-3685)
<b>Operating System:</b>	Windows Server 2003 R2 Standard x64 Edition, AcademicIncludes 5 CALs (420-5802)
<b>Mouse:</b>	Mouse Option None (310-0024)
<b>NIC:</b>	Embedded Broadcom NetXtreme II5708 GigabitEthernet NIC (430-1764)
<b>CD-ROM or DVD-ROM Drive:</b>	24X IDE CD-ROM for PowerEdge 2950 (313-3932)
<b>Sound Card:</b>	Bezel for PE 2950 (313-3920)
<b>Speakers:</b>	1x6 Backplane for 3.5-inch Hard Drives (311-5747)
<b>Documentation Diskette:</b>	Electronic Documentation and OpenManage CD Kit, PE2950 (310-7415)
<b>Additional Storage Products:</b>	146GB, SAS, 3.5-inch 10K RPM Hard Drive (341-3030)
<b>Feature</b>	Integrated SAS/SATA RAID 5 PERC 5/i Integrated (341-3060)
<b>Feature</b>	No Rack Rails Included (310-7411)
<b>Service:</b>	Dell Hardware Warranty Plus Onsite Service Inital YR (984-1399)
<b>Service:</b>	Basic Enterprise Support: Business Hrs 5X10 Tech Support 4HR Onsite Service Post Problem Diagnosis Init YR (970-4100)
<b>Service:</b>	Dell Hardware Warranty, Extended YR (984-1417)
<b>Service:</b>	Basic Enterprise Support: Business Hrs 5X10 Tech Support 4HR Onsite Service Post Problem Diagnosis 2YR Ext (960-8212)
<b>Service:</b>	BASIC Enterprise Support: Business Hrs 5x10 Hardware Only Tech Phone Support, 3Yr, Declined Software Support (960-8242)
<b>Installation:</b>	On-Site Installation Declined (900-9997)
<b>Misc:</b>	Redundant Power Supply with Y-Cord for PowerEdge 2950 (310-7421)
<b>Misc:</b>	146GB, SAS, 3.5-inch 10K RPM Hard Drive (341-3030)
<b>Misc:</b>	146GB, SAS, 3.5-inch 10K RPM Hard Drive (341-3030)
<b>Misc:</b>	146GB, SAS, 3.5-inch 10K RPM Hard Drive (341-3030)
<b>Misc:</b>	146GB, SAS, 3.5-inch 10K RPM Hard Drive (341-3030)
<b>Misc:</b>	3000VA UPS 120 Volt, Battery Backup and Protection ,2U RackMount (310-4352)

\$5517.52

<b>Base Unit:</b>	Dual Core Xeon Processor 5050,2x2MB Cache, 3.00GHz, 667MHz FSB, PE 2950 (222-2703)
<b>Processor:</b>	Dual Core Xeon 2nd Processor 5050, 2x2MB Cache, 3.00GHz, 667MHz FSB, PE 2950 (311-6085)
<b>Memory:</b>	2GB 667MHz (4X512MB), Single Ranked DIMMs (311-6153)
<b>Keyboard:</b>	No Keyboard Selected (310-5017)
<b>Video Card:</b>	Broadcom TCP/IP Offload EngineNot Enabled (430-1765)

Item # 6

Video Memory:	Riser with 2 PCI-X Slots (3 Volts) and 1 PCIe Slot for PowerEdge 2950 (320-4608)
Hard Drive:	300GB, SAS, 3.5-inch 10K RPM Hard Drive (341-3032)
Hard Drive Controller:	PERC 5/i, x6 Backplane Integrated Controller Card (341-3066)
Floppy Disk Drive:	No Floppy Drive for x6 Backplane (341-3685)
Operating System:	Windows Server 2003 R2 Standard x64 Edition, AcademicIncludes 5 CALs (420-5802)
Mouse:	Mouse Option None (310-0024)
NIC:	Embedded Broadcom NetXtreme II5708 GigabitEthernet NIC (430-1764)
CD-ROM or DVD-ROM Drive:	24X IDE CD-ROM for PowerEdge 2950 (313-3932)
Sound Card:	Bezel for PE 2950 (313-3920)
Speakers:	1x6 Backplane for 3.5-inch Hard Drives (311-5747)
Documentation Diskette:	Electronic Documentation and OpenManage CD Kit, PE2950 (310-7415)
Additional Storage Products:	300GB, SAS, 3.5-inch 10K RPM Hard Drive (341-3032)
Feature	Integrated SAS/SATA RAID 5 PERC 5/i Integrated (341-3060)
Feature	No Rack Rails Included (310-7411)
Service:	Dell Hardware Warranty Plus Onsite Service Initial YR (984-1399)
Service:	Basic Enterprise Support: Business Hrs 5X10 Tech Support 4HR Onsite Service Post Problem Diagnosis Init YR (970-4100)
Service:	Dell Hardware Warranty, Extended YR (984-1417)
Service:	Basic Enterprise Support: Business Hrs 5X10 Tech Support 4HR Onsite Service Post Problem Diagnosis 2YR Ext (960-8212)
Service:	BASIC Enterprise Support: Business Hrs 5x10 Hardware Only Tech Phone Support, 3Yr, Declined Software Support (960-8242)
Installation:	On-Site Installation Declined (900-9997)
Misc:	Redundant Power Supply with Y-Cord for PowerEdge 2950 (310-7421)
Misc:	300GB, SAS, 3.5-inch 10K RPM Hard Drive (341-3032)
Misc:	300GB, SAS, 3.5-inch 10K RPM Hard Drive (341-3032)
Misc:	300GB, SAS, 3.5-inch 10K RPM Hard Drive (341-3032)
Misc:	300GB, SAS, 3.5-inch 10K RPM Hard Drive (341-3032)
Misc:	3000VA UPS 120 Volt, Battery Backup and Protection ,2U RackMount (310-4352)

\$6527.90

You will also need a domain controller there, or nothing can work.

Base Unit:	Dual Core Xeon Processor 5050,2x2MB Cache, 3.00GHz, 667MHz FSB, PE 1950 (222-2398)
Processor:	Information,No Second Processor (311-1193)
Memory:	2GB 667MHz (4X512MB), Single Ranked DIMMs (311-6153)
Keyboard:	No Keyboard Selected (310-5017)
Video Card:	Broadcom Dual Port TCP/IP Offload Engine Key Not Enabled (430-1748)
Video Memory:	Riser with 2 PCI-X Slots (3 Volts) for PowerEdge 1950 (320-4816)
Hard Drive:	146GB, SAS, 3.5-inch 10K RPM Hard Drive (341-3030)
Hard Drive Controller:	PERC 5/i, Integrated Controller Card (341-3094)
Operating System:	Windows Server 2003 R2 Standard Edition, Includes 5 CALs (420-5796)
Mouse:	Mouse Option None (310-0024)
NIC:	Dual Embedded Broadcom NetXtreme II 5708 Gigabit Ethernet NIC (430-1762)
CD-ROM or DVD-ROM Drive:	24X IDE CD-ROM (313-3919)
Sound Card:	Bezel for PE 1950 (313-3937)
Speakers:	1x2 Backplane for 3.5-inch Hard Drives (311-5755)
Documentation Diskette:	Electronic Documentation and OpenManage CD Kit, PE1950 (310-7962)
Additional Storage Products:	146GB, SAS, 3.5-inch 10K RPM Hard Drive (341-3030)
Feature	Integrated SAS/SATA RAID 1 PERC 5/i Integrated (341-3084)
Feature	No Rack Rails Included, 1U (341-3089)
Service:	Dell Hardware Warranty Plus Onsite Service Initial YR (984-1519)
Service:	Basic Enterprise Support: Business Hrs 5X10 Tech Support 4HR Onsite Service Post Problem Diagnosis Init YR (970-3440)
Service:	Dell Hardware Warranty, Extended YR (984-1528)
Service:	Basic Enterprise Support: Business Hrs 5X10 Tech Support 4HR Onsite Service Post Problem Diagnosis 2YR Ext (960-7332)
Service:	BASIC Enterprise Support: Business Hrs 5x10 Hardware Only Tech Phone Support, 3Yr, Declined Software Support (960-7362)
Installation:	On-Site Installation Declined (900-9997)
Misc:	Non-Redundant Power Supply (310-7455)
Misc:	Maximum Partition Size Override for Microsoft WindowsFactory Installed Operating Systems (420-4018)

\$3297.50

For the addition in city hall, we can add 1 more drive to the NAS now plus up to another 12 drives on the cluster array. SCSI is for the cluster array, SAS is for the NAS. These are 146GB drives, we can go bigger if you want on the SCSI

146GB, U320,SCSI, 1 inch, 10K RPM Hard Drive, PE700, PV220 Customer Install (340-9387)

\$228.00

146GB, 3Gbps, SAS, 3.5 inch 10K RPM Hard Drive, Cold SpareCustomer Install (341-2826)

\$239.00

Item # 6

Let me know what kind of things you will want, thanks!

Sincerely,

Danny Falin





## Utility Committee Meeting

### AGENDA

August 7, 2007

**Item:**

MGAG - Legal Expenses

**Department:**

**Additional Information:**

**Financial Impact:**

**Budgeted Item:**

**Recommendation / Request:**

Viewing Attachments Requires Adobe Acrobat. [Click here](#) to download.

**Attachments / click to download**

[MGAG Legal Expenses](#)



Legal Expenses

**Bondurant, Mixson & Elmore, LLP**

<u>Date</u>	<u>Amount</u>	<u>Cumulative</u>
Jul 13-06	\$874.30	\$874.30
Aug 10-06	\$3,123.46	\$3,997.76
Sep 8-06	\$19,099.35	\$23,097.11
Oct 18-06	\$9,466.37	\$32,563.48
Nov 7-06	\$31,678.46	\$64,241.94
Dec 12-06	\$17,230.93	\$81,472.87
Jan 12-07	\$10,469.09	\$91,941.96
Feb 14-07	\$10,269.12	\$102,211.08
Mar 7-07	\$4,205.16	\$106,416.24
Apr 10-07	\$1,367.97	\$107,784.21
May 8-07	\$7,426.11	\$115,210.32
Jun 12-07	\$1,204.40	\$116,414.72
Jul 13-07	\$320.70	\$116,735.42
<b>Total</b>	<b>\$116,735.42</b>	

**Robert J. Middleton, Jr., LLC // HBSS**

<u>Date</u>	<u>Amount</u>	<u>Cumulative</u>
May 19-06	\$8,334.00	\$8,334.00
RJM Jun-Dec	\$65,548.50	\$73,882.50
		\$73,882.50
		\$73,882.50
		\$73,882.50
Jan 31-07	\$5,117.50	\$79,000.00
Feb 28-07	\$13,799.00	\$92,799.00
Mar 31-07	\$9,049.52	\$101,848.52
Apr 30-07	\$19,332.41	\$121,180.93
May 15-07	\$22,975.49	\$144,156.42
Jun 15-07	\$8,516.68	\$152,673.10
<b>Total</b>	<b>\$152,673.10</b>	

<u>RJM's Summary*</u>	
Jun	\$8,695
Jul	\$7,215
Aug	\$8,180
Sep	\$9,990
Oct	\$9,065
Nov	\$7,585
Dec	\$6,105
Sub-total	\$56,835
Expenses	\$5,684
Transcript	\$3,030
<b>Total</b>	<b>\$65,549</b>

**Grand Total**      **\$269,408.52**

<b>MGAG Share</b>	<b>\$134,704.26</b>
<b>Monroe Share</b>	<b>\$134,704.26</b>
<b>Grand Total</b>	<b>\$269,408.52</b>

\* Based on email from Bob Middleton; still awaiting actual invoices; which are reportedly en route.