

**CITY OF MONROE**  
**INVITATION TO BID**  
**SIDEWALK REPLACEMENT – WALTON ROAD**  
June 12, 2023



The City of Monroe is located between Atlanta and Athens metro areas with a diverse population of about 14,928 per the 2020 census, and serves as the county seat of Walton County. Monroe has a Council/Administrator form of government with a mayor elected at large and eight (8) councilmembers, who are elected by district or super-district. The mayor and members of the Council serve four-year terms, which are staggered by election.

The City of Monroe will be accepting Bids to contract services for the replacement of approximately 4,240 feet of sidewalk, curb and gutter, ADA ramps, and driveway aprons along Walton Road. The proposed timeline of the construction component of this replacement project is not to exceed thirty (30) days. Maps (Exhibit A) of the area are provided, but site visits are encouraged for better accuracy of the submission and do not require the City of Monroe to be present.

When downloading this document, please notify the City of Monroe at [purchase@monroega.gov](mailto:purchase@monroega.gov) of your company name and contact information, so that you may be copied on any additional addendums during the process. Any questions about this Invitation to Bid should be in writing only and directed to [purchase@monroega.gov](mailto:purchase@monroega.gov) prior to **5:00 pm on June 28, 2023**, at which point no other questions will be allowed (*all times referenced are considered Eastern Standard Time*). A full list of questions and answers will be provided to companies of record and posted on the website as an addendum no later than **5:00 pm on June 30, 2023**.

This project will be administered by the City of Monroe through the Assistant City Administrator and Central Services Manager being the main point of contact for all questions during preliminary procedures and the bidding process. After a contract is awarded a project manager will be designated.

**BID SCHEDULE**

The following outlines the timeline of dates to be followed for this specific bid process.

|                                    |               |         |
|------------------------------------|---------------|---------|
| Invitation to Bid                  | June 12, 2023 | 9:00 am |
| Question Due Date ( <i>EMAIL</i> ) | June 28, 2023 | 5:00 pm |
| Answers                            | June 30, 2023 | 5:00 pm |
| Submission Deadline                | July 13, 2023 | 3:00 pm |
| Contract Award                     | July 17, 2023 | 6:00 pm |
| Notice to Proceed                  | July 18, 2023 | 9:00 am |

**SCOPE OF SERVICES REQUESTED**

The following details the scope of services requested for the removal and installation of curb, gutter, and sidewalk along Walton Road. The work to be done consists of furnishing all labor, materials, and equipment for the sidewalk installation and replacement including but not limited to the demolition and disposal of existing concrete sidewalk, the construction of new curb and gutter (Exhibit B), concrete sidewalk, ADA ramps, driveway aprons, and related work for sidewalk reconstruction.

- 3,164 feet replacement of curb and gutter.
- 3,164 feet replacement of 5-foot sidewalk.
- 571 feet of new curb and gutter.
- 571 feet of new sidewalk.
- 500 feet replacement driveway aprons (25 driveways).
- Installation of 8 ADA ramps with red inlaid warning detector.
- Final grading with grassing.
- **NOTE:** all construction should adhere to Georgia Department of Transportation (GDOT) Construction Standards and Details (Exhibit B).
- **NOTE:** the contractor is responsible for calling and communicating with Georgia811 for all utility locates prior to start, and during construction of the project.
- **NOTE:** the contractor will provide traffic control in accordance with the Manual on Uniform Traffic Control Devices (MUTCD).
- **NOTE:** any damage to property by the awarded contractor is the sole responsibility of the contractor for repair and resolution.
- **NOTE:** no bid, performance, or payment bonds required.
- **NOTE:** timeline for completion is not to exceed thirty (30) days.

#### **SUBMISSION FORMAT**

The following outlines the formatted order of items required for bid submissions. All items should be included and clearly defined for ease of location and evaluation. Failure to include any requested items may result in the disqualification of the bid submission.

1. Company Information: Brief history of the company, date of incorporation, number of full-time employees, financial statements of the last fiscal year.
2. Reference: Provide a minimum of five (5) references for the installation/replacement of sidewalks in the State of Georgia. Include the name of the organization, city, county, contact name, contact information, project cost, and project start/completion dates.
3. Provide line-item pricing on the included pricing sheet (Exhibit C).
4. Timeline: Provide an anticipated starting date (*from proposed NTP of July 18, 2023*) and days expected to complete the described project.
5. Deviations: Explanation of any deviations to the specifications as outlined in this document.

#### **SUBMISSION**

Provide two (2) copies of the bid submission, including one (1) original. Bids may be submitted in person to the City of Monroe or by mail, but must be received no later than **3:00 pm on July 13, 2023**. Sealed bids shall be submitted in a completely sealed envelope, and addressed to:

City of Monroe  
**Sidewalk Replacement – Walton Road**  
 Attn: Chris Croy  
 215 North Broad Street  
 Monroe, GA 30655

**EVALUATION**

Evaluation of submitted bids will be based on the lowest bid that, in its sole discretion, is the most responsive and responsible to the City of Monroe. The City of Monroe reserves the right to shortlist, interview, and negotiate with those submitting bids.

**CONSIDERATIONS**

The City of Monroe reserves the right to withdraw this Invitation to Bid, reject any or all responses, and to waive any irregularity, variance or informality whether technical or substantial in nature, in keeping with the best interests of the City of Monroe. This bid plus the resulting agreement, shall be consistent with all terms and conditions associated with contracts entered into by the City of Monroe. The City of Monroe is not liable or responsible for any cost(s) incurred during the preparation, presentation, or submission as a response to this bid request.

The City of Monroe may, at its discretion, change, add or remove features and functions from final contract for the installation/relocation of natural gas mains at any time.

The submitted bid fee and structure shall remain effective for a period of no less than ninety (90) days.

Any unauthorized contact regarding the bid with staff or elected officials may result in disqualification. Any oral communications will be considered unofficial and non-binding on the City of Monroe.

We thank you in advance for your submission and welcome any questions you may have during the process.

Chris Croy  
Central Services Manager, City of Monroe  
215 North Broad Street, P.O. Box 1249  
Monroe, GA 30655  
(770) 266-5172

EXHIBIT A



**EXHIBIT B**

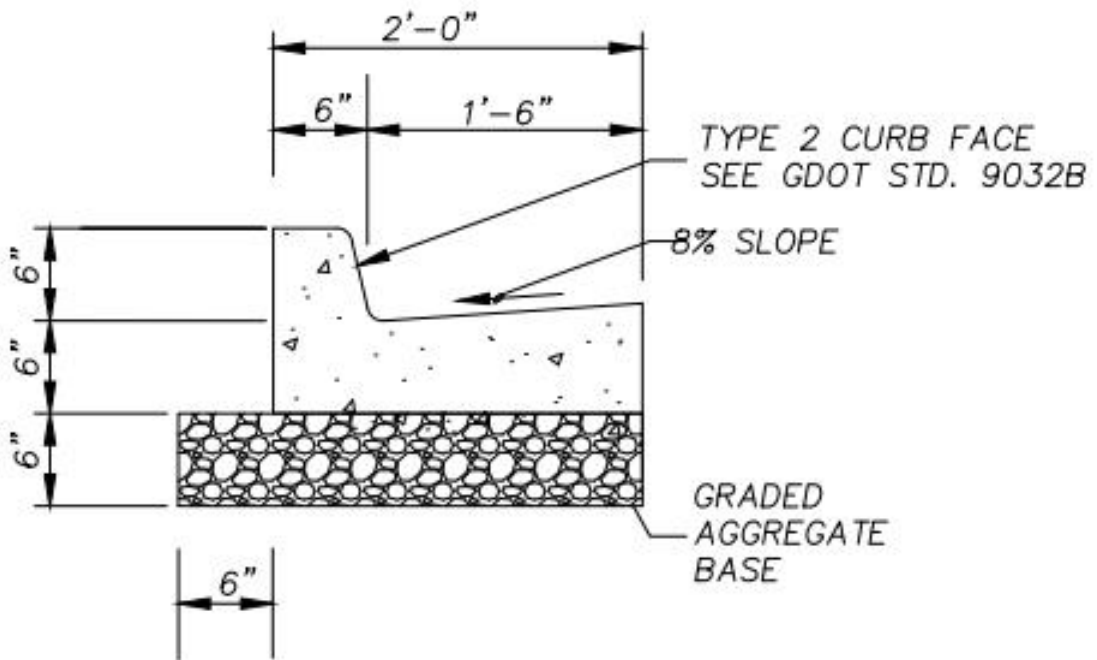

EXHIBIT C

| PRICE SHEET                               |               |              |            |             |
|---|---------------|--------------|------------|-------------|
| Item Description                          | Measure Units | Bid Quantity | Unit Price | Total Price |
| Replacement Curb & Gutter (demo included) | Feet          | 3,164        |            |             |
| Replacement 5' Sidewalk (demo included)   | Feet          | 3,164        |            |             |
| New Curb & Gutter                         | Feet          | 571          |            |             |
| New 5' Sidewalk                           | Feet          | 571          |            |             |
| Driveway Aprons (demo included)           | Feet          | 500          |            |             |
| ADA Ramp Installation                     | Unit          | 8            |            |             |
| Final Grading and Grassing                | Unit          | 1            |            |             |
|   |               |              |            |             |
|   |               |              |            |             |
|   |               |              |            |             |
|   |               |              |            |             |

Total Bid Price

| Additional Costs (if applicable) |
|----------------------------------|
|                                  |